

MULTI-RATIO ADVANCED GEARBOX KIT

DESCRIPTION

The *MULTI-RATIO ADVANCED GEARBOX* kit provides a choice of 4 gear ratios to choose from. There are also two motor options available (which must be purchased separately). Before starting assembly, the desired motor option and the gear ratio must be selected, as this defines the parts to be used, the assembly side and the assembling procedure.

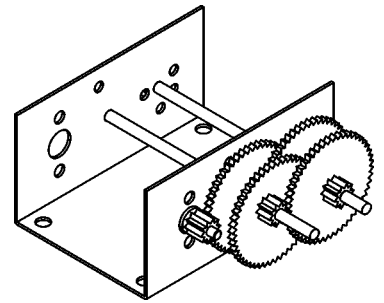

The *MULTI-RATIO ADVANCED GEARBOX*

1. GEARBOX AND MOTOR OPTIONS

<u>GEARBOX STAGE / Reduction ratio</u>	<u>OUTPUT SHAFT</u>	<u>RATIO</u>
Single reduction	Hole C	1:5
Double reduction	Hole D	1:18
Triple reduction	Hole C	1:64
Fourth Reduction	Hole D	1:228

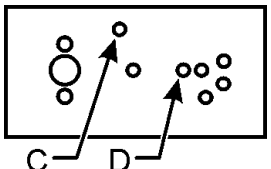

MOTOR OPTIONS:

The Gearbox can be used with either the S18 or the more powerful S28 motor.

<u>Standard Motor (S18) - Rated at 4.5V</u>	<u>Performance</u>
3 Volts: ie. Powered by 2xAA batteries	6,500 rpm ##
6 Volts: ie. Powered by 4xAA batteries	12,600 rpm ##
Torque	17.9 g.cm
<u>High Powered Motor (S28) – Rated at 9V</u>	
9 Volts	13,500 rpm
Torque	35 g.cm

Motor speeds quoted are approximate rpms under load

WARNING: Using a higher voltage increases the speed of the motor, but can reduce the life of the motor.

NOTE: as the two motors (ie S18 / S28) have different mounting and attaching screw holes, each particular motor is assembled on a different side of the Gearbox case (refer drawings). For this reason, the motor to be used must be determined prior to starting build.

2. COMPONENTS SUPPLIED.

2.1 *The following components are supplied in the kit:*

1x Multi-ratio Gearbox case	1x 10T Pinion gear 1.9 hole
2x M2.6x 4 self-tapping Screws	2x 50Tx14T Spur gears 2.4 hole (white)
2x 2.5 dia x120mm long steel rod	2x 50Tx14T Spur gear 2.6 hole (yellow)
1x 3mm inner dia 1.0 thick Washer	2x 12T Pinions 2.4 hole

2.2 Additional 50Tx14T yellow spur gears can be purchased, to create fifth, sixth etc ratios

3. ASSEMBLING THE MULTI-RATIO ADVANCED GEARBOX

The following instructions detail how to assemble a *MULTI-RATIO ADVANCED GEARBOX KIT*, using the S18 motor (the gears can be assembled onto the shaft/s with a help of small hammer).

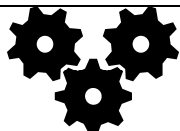

Rev'd: 20 April 2009

SCORPIO TECHNOLOGY VICTORIA PTY. LTD.

A.B.N. 34 056 661 422

17 Inverell Ave., Mt. Waverley, Vic. 3149

Tel: (03) 9802 9913 Fax: (03) 9887 8158 www.scorpiontechnology.com.au

NOTE: for this Gearbox, the holes marked 'C' & 'D' in the drawings are to be used - the supplied gears will not function if fitted to any other holes.

3.1 GENERAL

3.1.1 To assemble the *MULTI-RATIO ADVANCED GEARBOX KIT*, together with the higher powered S28 motor, the procedure is the same as detailed, except that the unit is „mirrored” –the motor is mounted on the other side of the Gearbox case (refer Section 4).

3.1.2 Before starting assembly, and depending on the intended use of the gearbox:

- determine the desired gearbox ratio –this defines which shaft is the axle (output shaft)
- define the length of the axle shafts, and cut (and de-burr) the steel rods to that length.

3.1.3 Notes:

- the 10T pinion gear (with a 1.9mm hole) is press fit on to the electric motor's 2.0mm shaft.
- the 12T pinions are used as locators.
- the white spur and 12T pinion gears (which have a 2.4mm hole) are press fit on to the 2.5mm shafts. The yellow spur gears have a 2.6 diameter hole, and are free wheeling on the shaft.
- the outside two 50T spur gears (ie one on each shaft, furthest from the gear case) must be the white, press fit gears

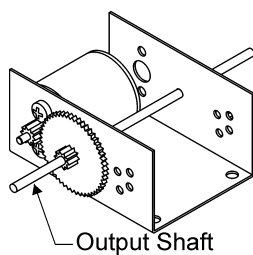

SINGLE REDUCTION
(Low ratio = high Output speed)

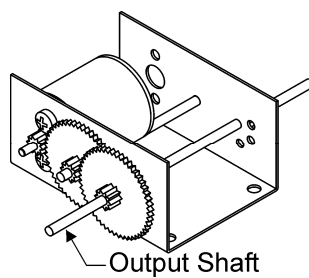

DOUBLE REDUCTION

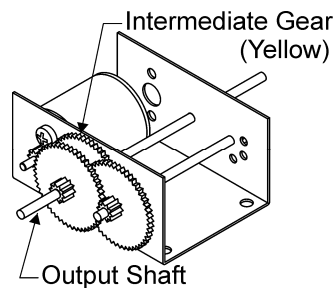

TRIPLE REDUCTION

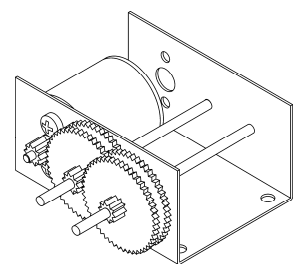

FOURTH REDUCTION
(High ratio = low Output speed)

3.2 ASSEMBLY PROCEDURE:

Assemble the steel rods, and all the gears, to the gearcase - as shown in the appropriate drawing– Single, Double, Triple or Fourth reduction. Also refer to the exploded diagram.

3.2.1 SINGLE REDUCTION

- Fit the shaft to the hole nearest the motor (Hole C), add the 12T pinion gear (locator), with the 1.0mm washer between the case and the (white) 50T spur gear.

3.2.2 DOUBLE REDUCTION

- Start by fitting the first shaft to the hole nearest the motor (Hole C), add the 12T pinion gear (locator), with the 1.0mm washer between the case and the (white) 50T spur gear
- Add the second shaft to Hole D, and add the 12T pinion gear (locator) and the (white) 50T spur gear.

3.2.3 TRIPLE REDUCTION

- Start by fitting the first shaft to the hole nearest the motor (Hole C), add the 12T pinion gear (locator), with the 1.0mm washer between the case and one (yellow) 50T spur gear
- Add the second shaft to Hole D, and add the 12T pinion gear (locator) and one (white) 50T spur gear.
- Install a (white) 50T Spur gear on the shaft nearest the motor.
- for the THIRD reduction ratio, this shaft is the output shaft.

3.2.4 FOURTH REDUCTION

- Start by fitting the first shaft to the hole nearest the motor (Hole C), add the 12T pinion gear (locator), with the 1.0mm washer between the case and a (yellow) 50T spur gear
 - Add the 2nd shaft to Hole D, and add the 12T pinion gear (locator) and the second (yellow) gear.
 - Install a (white) 50T Spur gear on the shaft nearest the motor.
 - Install the second (white) 50T Spur gear on the second shaft.
- for the FOURTH reduction ratio, this second shaft is the output shaft.

4. ASSEMBLING THE HIGH POWERED GEARBOX

The Gearbox is assembled in the same way as in Section 3., except that the motor is assembled to the opposite side of the gearcase, ie the other leg (as the motor spigot is larger for the 9Volt motor, and the attaching screw spacing is also different than for the 4.5 Volt motor).

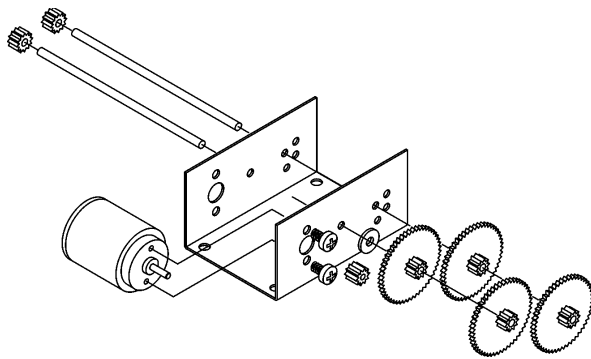

USING THE S18 MOTOR

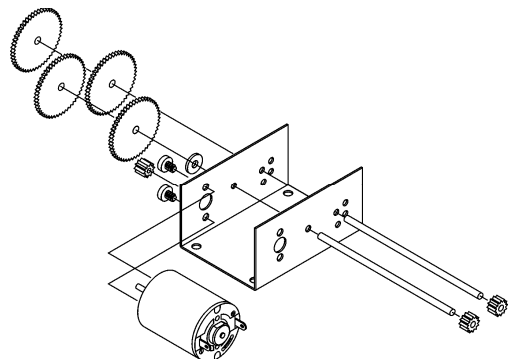

USING THE S28 MOTOR

5. ASSEMBLING THE MOTOR

- Press the 10T pinion onto the motor shaft. Hint: Place the gear on the bench, insert the motor shaft into the pinion gear's hole and gently tap the end of the shaft (where it exits the motor) with a small hammer. Stop when the worm gear is 3mm from the motor's body.

WARNING: Don't just push the motor down by hand, as this can push the motor armature out of its bearings and jam the motor.

- Solder a suitable length of wire to each of the motor's terminals. The length will be dictated by the planned usage and location of the Gearbox and other components.
- Secure the motor to the gearbox case using the two self-tapping screws.

6. ADDITIONAL REDUCTION RATIOS

- additional ratios can be created by adding more yellow 50T gears, onto the two shafts.
- regardless of how many additional 50T (yellow, free spinning) spur gears are added, only the outside two 50T spur gears (ie one on each shaft) must be white 50T gears.
- To add more gears, the shaft lengths may need to be longer, than possible with the supplied shaft. Packs of longer 2.5mm diameter shafts are available.