

RCV 27MHz PCB (Level B - un-assembled)

- PARTS LIST and ASSEMBLY INSTRUCTIONS

This is the instruction sheet for the "Level B" (un-assembled) Transmitter and Receiver PCBs, for the *RADIO CONTROLLED VEHICLE*. This must be used in conjunction with the RCV Teaching unit.

The PCB layouts and the Schematic diagrams are a part of this unit.

TRANSMITTER PARTS LIST		
REF NO.	SPECIFICATION	QTY
PRINTED CIRCUIT BOARD		
PCB	18701TX	1
INTEGRATED CIRCUIT		
IC	TX2B	1
CRYSTAL		
TX	27.145MHZ	1
TRANSISTOR		
Q1, Q2	2SC945	2
DIODES		
D2	4.3V ZENER	1
LED		
D1	RED LED 5 mm	1
INDUCTOR		
L1	6R8K - 6.8 μ H	1
L2	1R0K - 1 μ H (wire wound)	1
L3, L4	2R2K - 2.2 μ H	2
SW		
SW1	SLIDE	1
CAPACITORS		
C5	40P + - 5%	1
C4, C6	82P + - 5%	2
C8, C9	101P + - 5%	2
C10	56P + - 5%	1
C1	203Z	1
C3, C7	103Z	2
C2	47 μ F + - 10% 10 V	1
RESISTORS		
R6, R8	100 Ω + - 5% 1/4W	2
R2	330 Ω + - 5% 1/4W	1
R1	470 Ω + - 5% 1/4W	1
R4	5.6 K Ω + - 5% 1/4W	1
R5	33 K Ω + - 5% 1/4W	1
R7	220 K Ω + - 5% 1/4W	1
R3	240 K Ω + - 5% 1/4W	1
ANTENNA BRACKET		

PARTS MOUNTED ON MOTOR		
CAPACITORS		
C14 (for M2)	473 Z	1
C15 (for M1)	473 Z	1

RECEIVER PARTS LIST		
REF NO.	SPECIFICATION	QTY
PRINTED CIRCUIT BOARD		
PCB	18701RX	1
INTEGRATED CIRCUIT		
IC	RX2B	1
TRANSISTOR		
Q1	S9013	1
Q2, 5, 8, 11, 14	2SC945	5
Q9, Q12	B564AY	2
Q10, Q13	D471AY	2
Q4, Q7	HIT5609	2
Q3, Q6, Q15	HIT5610	3
DIODES		
D1	3.3V ZENER	1
INDUCTOR		
L2	LGA0307 - 3R3K - 3.3 μ H	1
OSC COIL		
L1	7 1/2T	1
CAPACITORS		
C1	4P + - 5%	1
C2	33P + - 5%	1
C3	M/C 332K or J	1
C4	20P + - 5%	1
C5	3.3 μ F + - 10% 10 V	1
C6	203 Z	1
C7	473 Z	1
C8	501P + - 10%	1
C9	103 Z	1
C10	222 Z	1
C11	102 Z	1
C13	100 μ F + - 10% 10 V	1
RESISTORS		
R14, 16, 19, 21	82 Ω + - 5% 1/4W	4
R4	470 Ω + - 5% 1/4W	1
R1, R8	680 Ω + - 5% 1/4W	2
R5, 13, 15, 17, 18, 20	1K Ω + - 5% 1/4W	6
R3, R6, R11	3.3K Ω + - 5% 1/4W	3
R12	330K Ω + - 5% 1/4W	1
R2, R9	390K Ω + - 5% 1/4W	2
R7, R10	3.9M Ω + - 5% 1/4W	2

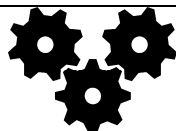

SCORPIO TECHNOLOGY VICTORIA PTY. LTD.

A.B.N. 34 056 661 422

17 Inverell Ave., Mt. Waverley, Vic. 3149

Revised: 29th June 2009

Tel: (03) 9802 9913 Fax: (03) 9887 8158 www.scorpiotechnology.com.au

1. PCB ASSEMBLY

1.1 INSTRUCTIONS FOR TEACHERS

Constructing these PCBs is reasonably difficult. Ideally students need some previous experience at constructing and testing electronic projects. For this a good understanding of the various components and their symbols is useful. It is important that students understand the symbols and general principles of the various electronic components before they begin their project.

1.2 PCB CONSTRUCTION DETAILS

Both the transmitter and receiver PCBs have a silk screen overlay, which is printed on the PCBs, to locate the components. For clarity on the Receiver's component location, refer page 8.

Assembly

Before soldering, all components must be checked to make sure they're correctly placed. The components are soldered. The component leads must be trimmed 1 to 2 mm from the PCB. Note: Before applying power, check soldering for "dry joints" and solder bridges across tracks.

Tuning

The prototype PCB's were found to work without adjusting the receiver tuner L1. If adjustment is needed, use a small plastic rod with the end pointed like the end of a screwdriver. Make sure that metal screwdrivers are not used. Any metal (even brass) will affect the adjustment.

Transistors

Be very careful that the numbers marked on the transistors are the same as on the parts list.

Note: They may look the same, but if they are swapped around the PCB will not work.

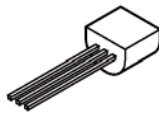

Integrated Circuits

These components look like beetles with lots of legs! They have a notch (or dimple) at one end.

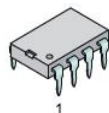

These must be placed on the PCB with the notch facing in the same direction as shown on the PCB. If power is connected to the PCB with these facing the wrong way, the PCB will not work and the Integrated Circuit will be permanently damaged.

Resistors

Resistors are marked on the PCB as R1, R2, etc.

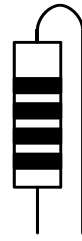

Bend one lead of the resistor 180° as shown on the left.

Insert the leads through the holes in the PCB until the body of the resistor rests **just above or on** the PCB..

Bend the leads out slightly on the track side. This will prevent the resistors from slipping down when the board is turned upside down during soldering.

Use the colour code chart to determine the value of each resistor.

Resistance	Preferred Notation			
				Tolerance
82 Ohm	82R	Grey	Red	Black
100 Ohm	100R	Brown	Black	Brown
330 Ohm	330R	Orange	Orange	Brown
470 Ohm	470R	Yellow	Violet	Brown
680 Ohm	680R	Blue	Grey	Brown
1k Ohm	1k	Brown	Black	Red
3.3k Ohm	3k3	Orange	Orange	Red
5.6k Ohm	5k6	Green	Blue	Red
33k Ohm	33k	Orange	Orange	Orange
220k Ohm	220k	Red	Red	Yellow
270k Ohm	270k	Red	Violet	Yellow
330k Ohm	330k	Orange	Orange	Yellow
390k Ohm	390k	Orange	White	Yellow
3.9M Ohm	3M9	Orange	White	Green

The resistors values are marked with coloured bands. These are the resistor colour codes. The coloured bands for are given below.

0 - Black	5 - Green	20% - No stripe
1 - Brown	6 - Blue	10% - Silver stripe
2 - Red	7 - Violet	5% - Gold stripe
3 - Orange	8 - Grey	
4 - Yellow	9 - White	

Capacitors

There are 3 types of capacitors used:

Disk Ceramic

These are like a round disk with two leads. They can be placed either way round. The value is marked on one side. The codes that are marked are shown below.

10pF	10
15pF	15
47pF	47
82pF	82
100pF	100 or 101
500pF	500 or 501
2.2nF	222
10nF	103
20nF	203
47nF	473



The negative lead goes to the end that D1's arrow symbol (on the PCB) points towards.

Zener Diode

D1 is a 4.2v or 4.3v Zener diode. It has "4v2" or "4v3" marked on its body. A magnifying glass will probably be needed to read it.

The diode has a black band on one end. This end corresponds to the end that D2's arrow symbol points towards.

- this must be mounted in the correct direction.



Crystal

The crystal has a bright metal body with 27.125 marked on it, and can be connected either way.

Electrolytic

These have a cylindrical body with a stripe down one side. The stripe indicates the negative terminal and they must be connected correctly or the PCB will not work.

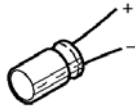

GreenCap (Metallised Polyester)

These are rectangular, usually green, and can be mounted either way round. The value is printed on one side. There is only one GreenCap used in this project. It could be marked as either:



3.3nF: 332 or 0.0033μF

1.3 TRANSMITTER

The PCB has a large cut out hole in its centre.

Inductors

There are four inductors used. They look like large resistors. They are:

- L1: Blue, Grey, Gold, Silver
- L2: Brown, Black, Gold, Gold
- L3 and L4: Red, Red, Gold, Silver

The inductors can be mounted in either direction.

Light Emitting Diode (LED)

This is used to indicate when the transmitter is on. The negative lead can be identified in one of three ways (although not all LEDs use methods 2 & 3. The methods are :

1. The flag (the larger connection inside the body) identifies the negative lead. This is visible when the LED is held up to the light
2. The shortest leg is negative
3. A flat on the ridge, around the base of the LED is on the negative side.

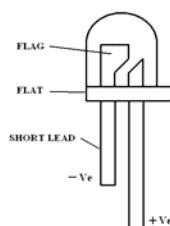

Inductors

This PCB uses one type of inductor: L1 is a variable type. This has a plastic body with copper wire wound around its body. It will only fit on the PCB one way round.

Resistors

Position R22 is not marked on the PCB - its holes are directly between R3 C5 (to the right of R3)



Transistors

A large number of transistors are used. Be careful that the numbers marked are the same as on the parts list. They may look the same, but if any are swapped around the PCB will not work. Connection positions for the transistors Q1(s9013) and Q5(2SC945) are marked different to the other transistors. Connect the leads as per marking, refer illustrations below.

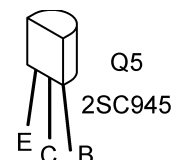
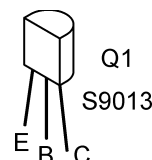

2. WIRING UP THE PCBs

2.1 GENERAL:

After the PCBs have been assembled, a number of parts need to be connected to the PCBs. This section details what is connected, and where.

- This unit must be used together with the "RADIO CONTROL VEHICLE (Mark 3)" Teaching unit.

The picture of the reverse side of the PCB (ie. The PCB layout) provides soldering instructions for the PCBs. When soldering the wires, be careful to use a minimal amount of solder (to avoid overrun)

2.2 THE TRANSMITTER (CONTROL UNIT):

- Use the 9 volt battery clip for the battery connection to the transmitter.
- An On/Off switch is mounted on the PCB, and soldered in place – this is the Transmitter's On-Off switch, and is an integral part of the PCB / kit.

Note: A LED on the PCB is used to indicate when the unit is switched on.

THE TRANSMITTER PCB

Connect numbers marked on this drawing to the like numbered points on the 2 switches: SW2 and SW3.

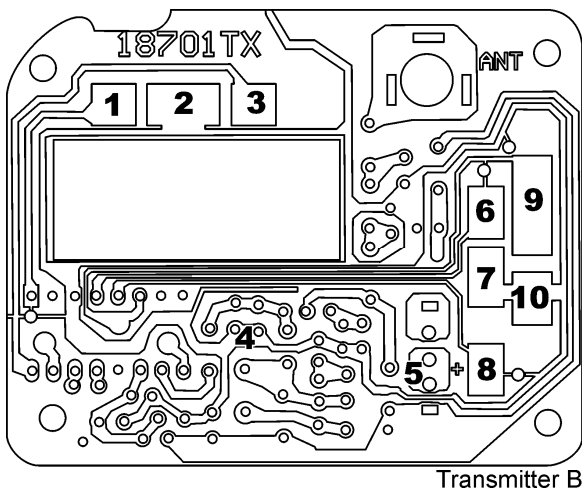

1. SW2 – position 1
2. SW2 - position 2
3. SW2 - position 3
4. Battery clip –ve (Black)
5. Battery clip +ve (Red)
6. SW3 – position 6
7. SW3 – position 7
8. SW3 – position 8
9. SW3 – position 9
10. SW3 – position 10

STEERING SWITCH - SW2

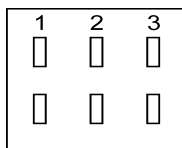

FORWARD / REVERSE SWITCH - SW3

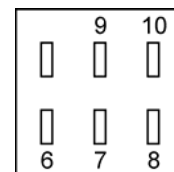

NOTE: Both switches are shown looking at their terminals (i.e. from the rear of the switch)

WIRING INSTRUCTIONS

- Cut nine wires the same length. Three are for the steering switch (SW2) and the remainder for the Forward/ Reverse switch (SW3). Strip 5 mm off the insulation from both ends of the wires. Twist the bare strands together tightly. Tin one end of each wire. Cut the tinned ends of the wires back to about 3mm long.
- Tin the Printed Circuit Board pads, to which the switch wires will be soldered (refer the PCB illustration).
- Hold the tinned wire ends onto the tinned pads and heat both with the soldering iron (the solder on the wires and pads should melt into each other).
- Put the un-tinned ends of the wires through the holes of the switch terminals. Solder the wires and cut off the excess wire as close to the terminal as possible.

Note: Take care to ensure the *Positive and Negative* wires are the correct way round.

2.3 THE RECEIVER PCB (VEHICLE MOUNTED): THE RECEIVER PCB

Connect the numbers marked on the PCB drawing to the following :

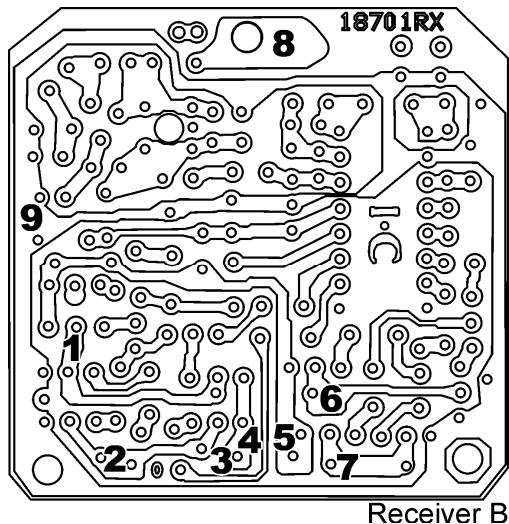

Receiver B

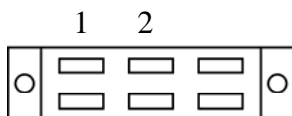

PCB CONNECTIONS:

1. Steering motor
2. Steering motor
3. 4xAA Battery +ve (Red)
4. 2xAA Battery -ve (Black)
5. To SW1 position 2
6. Drive motor
7. Drive motor via inductor L4
8. Antenna
9. 4xAA Battery -ve (Black)

ON / OFF SWITCH - SW1:

1. To +ve (red) - 2x AA batteries
2. To "5" on the PCB

Soldering should be carried out in the following order:

- Wire the switch in place as shown in the diagram.
- Solder the switch, battery connections and antenna.
- Solder the wires to the motors (after testing the direction of the wheels rotation).

NOTE: If you look at the Receiver's Schematic diagram, you will see that the two sets of battery holders connect together. The +ve wire from the 4AA battery holder is connected to the -ve wire of the 2AA battery holder.

- When the battery holders are connected this way, 9Volts are supplied to the control circuitry, and 6 volts are supplied to the motor section.

WIRING INSTRUCTIONS

- Cut the wires needed for the various PCB connections. Strip 5 mm off the insulation from both ends of the wires. Twist the bare strands together tightly. Tin one end of each wire. Cut the tinned ends of the wires back to about 3mm long.
- Tin the PCB pads, to which the switch wires will be soldered.
- Hold the tinned wire ends onto the tinned pads and heat both with the soldering iron (the solder on the wires and pads should melt into each other).
- Put the un-tinned ends of the wires through the holes of the switch terminals. Solder the wires and cut off the excess wire as close to the terminal as possible.
- Capacitors C14 and C15 are soldered directly across the terminals of the steering and drive motors to suppress RF interference – one for each motor (Refer to the schematic diagram).

SCHEMATIC DIAGRAM - RECEIVER (27 MHz – LEVEL B)

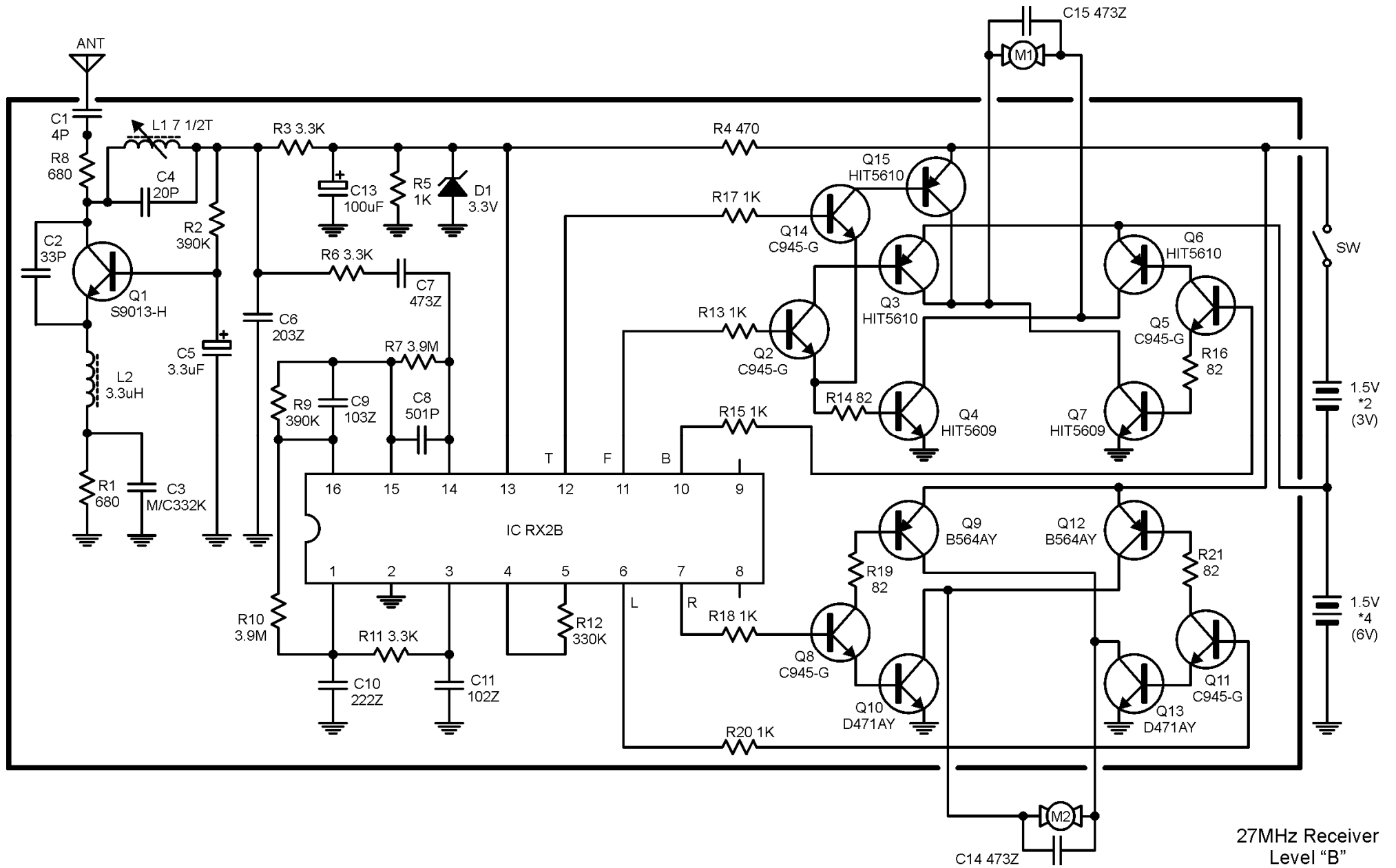

27MHz Receiver
Level "B"

SCHEMATIC DIAGRAM - TRANSMITTER (27 MHz – LEVEL B)

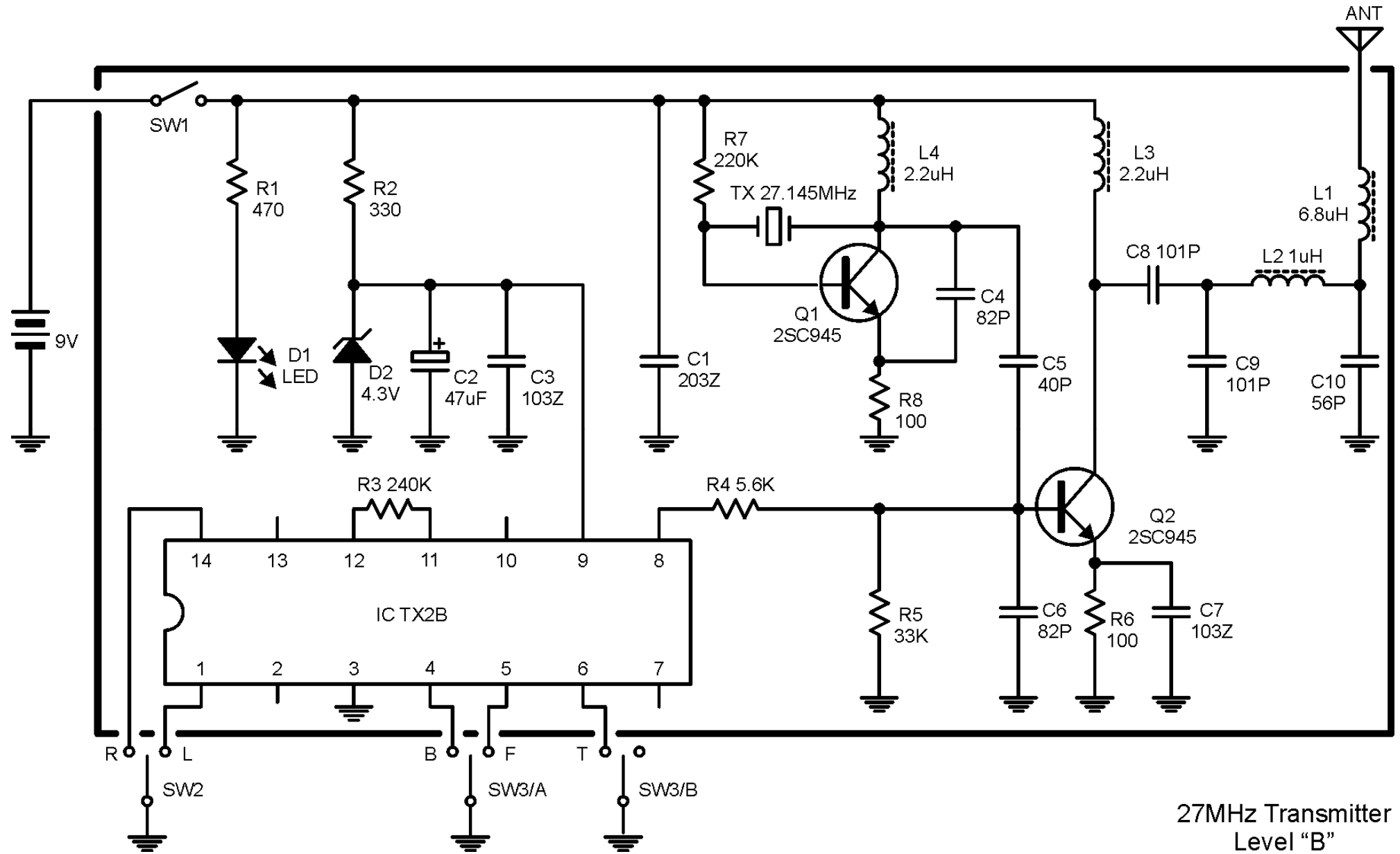

27MHz Transmitter
Level "B"

COMPONENT LOCATION ON THE RECEIVER PCB

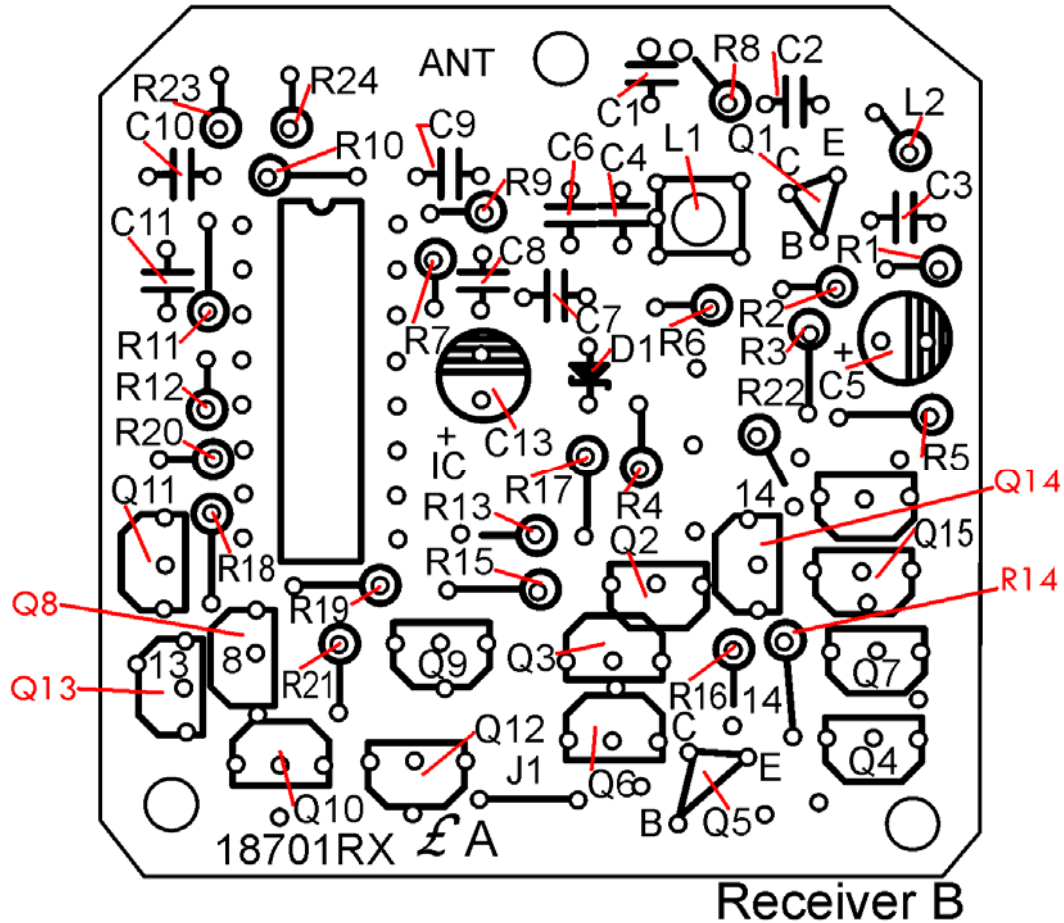

NOTES:

1. refer Section 1.4 Receiver, " Transistors", for more information
2. the red lines on this diagram, are to clarify component location on the Receiver PCB
3. Refer the illustrations below, to identify the orientation of components Q1 and Q5

