

BALANCE PLANE

DESCRIPTION

In this project a beam is used, with an electric motor and a propeller on one end and a battery holder on the other end. It is placed in a balanced state, on a vertical upright.

This beam is designed to be rotated about its central point, in a horizontal plane, by the motor-driven propeller.

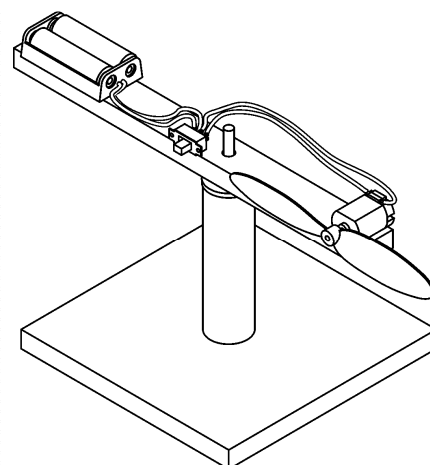

1. COMPONENTS REQUIRED

1.1 COMPONENTS SUPPLIED

The following components are supplied in a plastic bag :

1x	3.0V Electric Motor (flat)	1x	Propeller 151 mm long
1x	Sliding Switch (small)	2x	Washers 3.0mm ID
1x	2 x AA Battery Holder		

1.2 ADDITIONAL REQUIREMENTS

1.2.1 Available from us are 2.3mm drill bits and 2 x AA batteries, and need to be ordered separately.

1.2.2 The additional requirements are: material for the beam, base and upright, fine electric wire, a 3.0mm drill bit, one 2.5mm diameter nail, hot glue or double sided foam tape.

2. DESIGN

The major aspects of this project are the planning, design, construction and assembly stages.

2.1 GENERAL:

- The basic construction is shown in the drawing. The students should make a drawing to determine the overall size of the device.
- Different length beams will rotate at different speeds
- The base must be fairly sturdy so that the device can not fall over. For the upright a piece of dowel is best, as this can be inserted in a hole drilled in the base.
- The equilibrium point (centre of balance) should be determined after the components have been assembled on the beam.

2.2 THE BEAM:

- The rotating beam can be made from wood, plywood, balsa or plastic.
- The beam needs to be large enough not to flex. For example, a beam 15 x 15 mm should be adequate.
- The width of the beam needs to be sufficient for all components to be securely mounted.
- The weight of the beam will affect the acceleration ie. a lighter beam provides faster acceleration. The weight is determined by the size of the beam, and the density of the material chosen. For example, compare a piece of balsa wood, and a piece of hardwood.
- The beam should be assembled and balanced before mounting it on the vertical support.

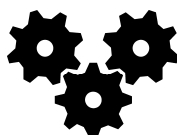

Revised: 29th May 2009

SCORPIO TECHNOLOGY VICTORIA PTY. LTD.

A.B.N. 34 056 661 422

17 Inverell Ave., Mt. Waverley, Vic. 3149

Tel: (03) 9802 9913 Fax: (03) 9887 8158

www.scorpiotechnology.com.au

3. CONSTRUCTION

- Cut the rotating beam to the desired size and length, and make the base and upright.
- Press the propeller on to the motor's shaft. HINT: Place the end of the shaft (where it exits the motor) on a hard surface, and push the propeller down. WARNING: Don't just push the motor down by hand as this can push the motor armature out of its bearings and jam the motor.
- Attach the motor and propeller to one end of the beam and the battery holder to the other end. The switch is to be mounted approximately midway along the beam and it should be located so as not interfere with the pivot. If hot glue is used, the surfaces should be roughened with sandpaper. An alternative to this is double-sided foam tape.
- Once the beam is constructed and assembled, the equilibrium point (centre of balance) needs to be determined. This must be done with the batteries in place. The equilibrium point can be found by placing the beam on the edge of a ruler. Start at the middle of the beam and keep moving it until the beam balances on its own. Drill a 3.0 mm diameter hole through the centre of the beam at this point. If after drilling the hole the beam does not balance, place some blu-tack or plasticine on the light end until it balances.
- Cut the material for the base and upright. Fasten the upright in place on the base. Drill a guide hole in the top end of the upright and drive into it a 2.5 mm diameter nail (with the head cut off).
- Place two washers on the nail and install the beam in place. The washers minimise the friction generated during rotation.

4. WIRING

The Switch should be wired as shown in the "Wiring Schematic"

- Solder both the battery holder's wires to both of the terminals at one end of the switch.
- Solder two wires to the switch's middle terminals. Connect the other ends of those two wires to the motor's terminals. If the plane spins in the correct direction, solder the wires to the terminals. If it goes in the wrong direction, swap the wires & then solder them.

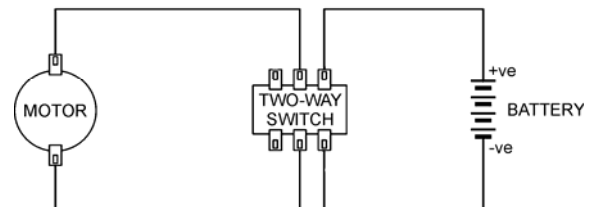

WIRING SCHEMATIC

5. WHAT TO DO WITH THE BALANCE PLANE?

The balance plane is completed! Now what?

The beam's design and simplicity of construction allow for further work and some experimentation. For example:

- Count the times the beam rotates in one minute (r.p.m. – revolutions per minute).
- Work out at what speed the end of the beam is travelling
- Work out the distance travelled by the motor in one minute.
- Remove both washers. Use one washer. Smear oil between both. See what effect (if any) friction has on the speed.
- If the propeller and battery holder are not permanently attached, see if altering the positions (ie. closer to the centre) affect the r.p.m. and speed. (Alternatively, make different length beams as a class.
- Does adding a balanced weight onto the beam change the rate it moves?