

BELT DRIVEN CAR

(NO SOLDER KIT)

CONTENTS:

Section 1: General and Planning information
Section 2: Components and Material required

Section 3: Fabrication & assembly
Section 4: Wiring up the *BELT DRIVEN CAR*

DESCRIPTION

This is a four wheeled vehicle at its simplest. Motive power is provided to the rear axle by an electric motor-driven belt (a rubber "O" ring).

A number of these cars can be raced, and have the potential to be added to, to drive faster! Also, car bodies can be built, and decorated in the Art class!

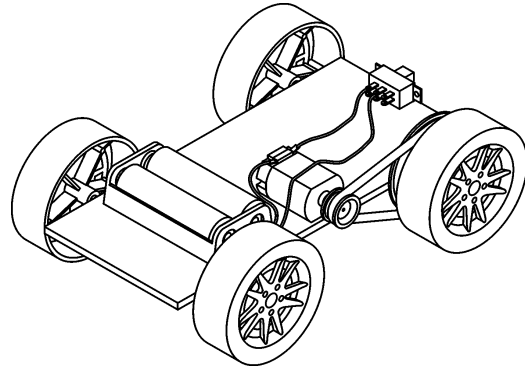

SECTION 1: GENERAL AND PLANNING INFORMATION

THE PROJECT

The major parts of this project are the vehicle's planning, design, construction and assembly stages. To this can be added such things as usage and performance .

DESIGN

- The drawings in this unit show the basic construction of the vehicle.
- The student has to make a full size drawing to determine the size of the vehicle's platform, the size and position of wheels, and the location of the motor, switch and battery holder. The body can be made from a single long piece of wood or plastic. Weight distribution and ease of operation should be taken into account.
- The PVC guide tubes are used as bearings for the axles, and are attached (glued) to the platform. The tubes should be 2-3 mm longer than the width of the platform. This prevents the wheels rubbing against the base, and slowing the vehicle down.
- When defining the width of the vehicle, the axle shaft provides an upper limiting factor. However, if a much wider vehicle is desired, cut-outs can be made for the wheels to allow wider material to be used (for an example, refer to the DRAGSTER unit on our website)
- In regard to the width, the platform can be made from any piece of material, even a very narrow one, but stability needs to be considered.
- With this vehicle only fixed steering is possible. However, you may wish to make it, so that the steering turns the car in one direction all the time, by mounting the front axle at a slight angle.

NOTE: while this vehicle at its most basic, it also allows scope for the student to develop and make a more interesting vehicle. Students can fabricate a body to simulate a monster truck, hot rod or other vehicle.



SCORPIO TECHNOLOGY VICTORIA PTY. LTD.

A.B.N. 34 056 661 422

17 Inverell Ave., Mt. Waverley, Vic. 3149

Issued: 18 March 2011

Tel: (03) 9802 9913 Fax: (03) 9887 8158 www.scorpiotechnology.com.au

SECTION 2: COMPONENTS & MATERIAL REQUIRED

2.1 COMPONENTS SUPPLIED. The following components are supplied in a plastic bag:

1 x	3V electric motor (flat – with wires)	1 x	Sliding switch – on/off (small)
2 x	2.5 steel shaft – 120mm long	1 x	O-ring (belt) – 45 mm
2 x	PVC Guide tube (white) 100mm long	1 x	5.5mm diameter pulley
4 x	Wheels 52mm diameter	1 x	30mm diameter pulley
1 x	2xAA battery holder		

2.2 ADDITIONAL REQUIREMENTS

2.2.1 Available from us are AA batteries, single and double sided tapes, and these need to be ordered separately.

2.2.2 The additional requirement is material for the platform.

Note: it is suggested that, before you commence construction, you check the components supplied in your kit, and ensure that you have everything required.

SECTION 3: FABRICATION & ASSEMBLY

3.1 FABRICATION AND PREPARATION FOR ASSEMBLY

- Cut the platform material to the required size and shape.
 - Cut the axles to length. To determine the length of the axle, place a nail or piece of wire into the wheel hole to measure its depth. The length of the steel rod needed is worked out by taking the length of the plastic tube plus 2 times the depth of the wheel hole (for both wheels) plus 2 mm for clearance (so the wheel will not jam up against the platform).
- NOTE: When working out the rear axle length, remember to allow for the pulley as well.
- Deburr the steel shaft ends with a file. Deburring is smoothing the rough edges or any other part of the metal that needs a smooth surface.

3.2 ASSEMBLING THE CAR

- Assemble the pulley to the motor.

HINT: Place the gear on the bench, insert the motor shaft into the pulley's hole and gently tap the end of the shaft (where it exits the motor) with a small hammer.

WARNING: Don't just push the motor down as this can push the motor armature out of its bearings and jam the motor.

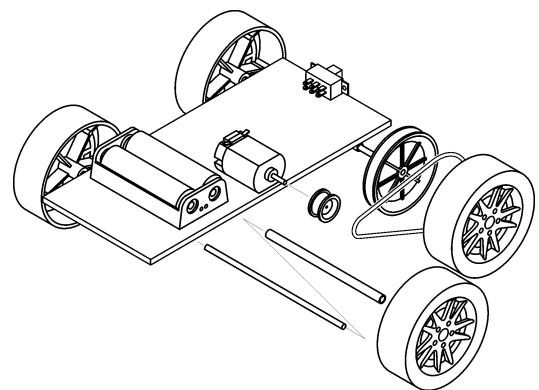

- Attach the motor, switch and battery holder on to the chassis using double sided foam tape or hot glue or (if using hot glue, roughen the surfaces to be glued with sandpaper to improve adhesion).

WARNING: if using Hot glue, be very careful, as it can burn you, if you get it on yourself.

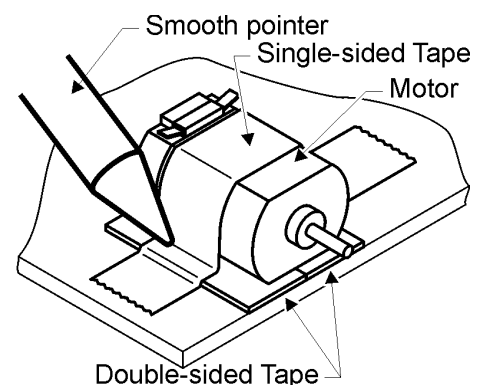

- Glue the plastic tube in place on the platform. Make sure that the tube is straight and not on an angle (or the vehicle will steer to one side).

NOTE: Ensure that the axles guide tubes are at right angles to the car body and both guide tubes are parallel to each other.

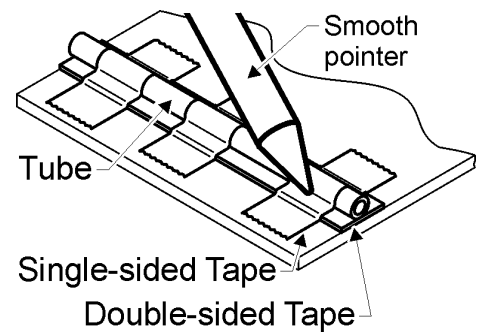

- With the axle shafts in place, carefully press the 30mm pulley and wheels on to the shafts.

WARNING: if using hot glue, be aware that hot glue can heat up the plastic tube and cause it to bend, making the axle a tight fit. To prevent this, and keep the plastic tube straight, place the axle through the plastic tube before gluing and hold the axle down until the glue sets.

SECTION 4: WIRING UP THE *BELT DRIVEN CAR*

The Switch should be wired as shown in the "Circuit diagram"

- Connect the battery holder's red wire to one of the red wires from the switch. Twist them firmly together.
 - Connect the switch's other red wire, to the motor's red wire. Twist them firmly together.
 - Twist the black wires from the motor and battery holder together.
 - Insert the batteries, and turn the switch on,
 - if the vehicle moves forward, your wiring is correct.
 - If the vehicle goes in reverse, you will need to swap the motor's wires.
- Note: Remove the motor's red wire from the switch and untwist the black wires from the motor and battery holder. Twist the red wire from the motor to the black wire from the battery holder. Connect the motor's black wire to the remaining red wire on the switch. Twist them firmly together.
- Apply insulation tape to the joined wires.

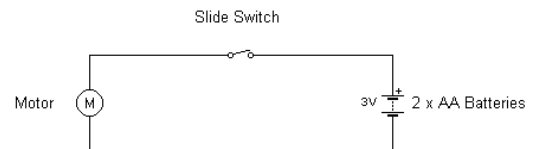

CIRCUIT DIAGRAM

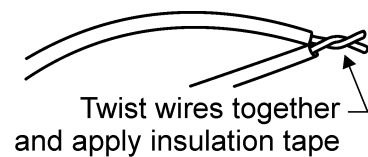

Note: this kit has components that allow this to be assembled without soldering. However, the connections will be more effective and permanent if they are soldered.

The vehicle is now complete.

CONGRATULATIONS! YOU HAVE BUILT YOUR *BELT DRIVEN CAR!*