

CAPTIVE AEROPLANE

(NO SOLDER KIT)

CONTENTS:

Section 1: General and Planning information
Section 2: Components and Material required

Section 3: Making *CAPTIVE AEROPLANE*
Section 4: Wiring up *CAPTIVE AEROPLANE*
Section 5: Using the *CAPTIVE AEROPLANE*

DESCRIPTION

A small aeroplane is built from plastic or wood. It is driven by a propeller, which is powered by a small electric motor. The plane is suspended from an overhead point and flies in a circle.

The basic *CAPTIVE AEROPLANE* is a very simple model to construct. This has a lot of scope for combining two different areas of study: technology and art (with a bit of woodwork thrown in!).

The aeroplane is a simple model to make. However the components and ideas can be used to make other devices. For example:

- A witch on a broomstick
- A flying pig (see if pigs can really fly?)

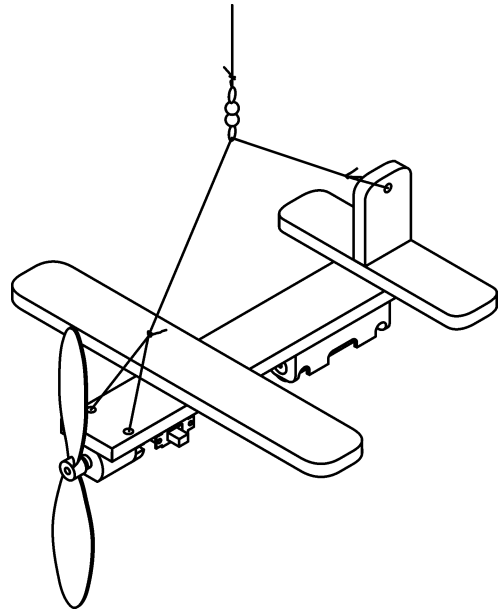

SECTION 1: GENERAL AND PLANNING INFORMATION

DESIGN

The basic design is as shown in the drawing – wings, a fuselage and a power source. The design allows each designer scope in the shape and size of the plane.

The student needs to make a full size drawing, before starting construction. This allows planning the location of components and working out the size of the body and wings. We made our prototype's body from a 10 mm wide strip of plywood approx 220 mm long. The wings can be made from balsa sheet, heavy hardboard or plastic, with the dimensions to suit the fuselage. Note: if cardboard is used for the wings, the use of a brace is suggested.

The aim is to design the plane, so that it is (ideally) balanced around the mid-point. Note that:

- the center of balance is affected by the weight of the components and their placement (relative to the centre), and should be placed with the aim of balancing the plane
- the heavier components should be mounted underneath the aeroplane's fuselage, for a better centre of gravity

SECTION 2: COMPONENTS & MATERIAL REQUIRED

2a COMPONENTS SUPPLIED. These components are supplied in a plastic bag :

1x	3.0V Electric Motor (flat) – with wires	1x	1 x AA Battery Holder
1x	Sliding Switch (small) – with wires	1x	Propeller 74 mm long



SCORPIO TECHNOLOGY VICTORIA PTY. LTD.

A.B.N. 34 056 661 422

17 Inverell Ave., Mt. Waverley, Vic. 3149

Rev'd: 18 March 2011

Tel: (03) 9802 9913 Fax: (03) 9887 8158 www.scorpiotechnology.com.au

2b ADDITIONAL REQUIREMENTS

2b.1 Available from us is the penlight (AA) battery and fishing line

2b.2 You need to supply: material for the aeroplane body (ply, balsa or dowel) and wings (balsa or plastic), fine electric wire, a snap swivel (used in fishing to connect lures), double sided foam tape or hot glue.

Note: it is suggested that, before you commence construction, you check the components supplied in your kit, and ensure that you have everything else required.

SECTION 3: MAKING AND ASSEMBLING THE CAPTIVE AEROPLANE

- Cut the material for wings and tail to the designed size.
- Construct and attach the wings and tail to the body..
- Press the propeller on to the motor shaft.

HINT: Place the end of the shaft (where it exits the motor) on a hard surface, and push the propeller down.

WARNING: Don't just push the motor down by hand as this can push the motor armature out of its bearings and jam the motor.

- Attach the motor, switch and battery holder underneath the body using double sided foam tape or hot glue (roughen the surfaces to be glued with sandpaper to improve adhesion).

WARNING: if using Hot glue, be very careful, as it can burn you, if you get it on yourself.

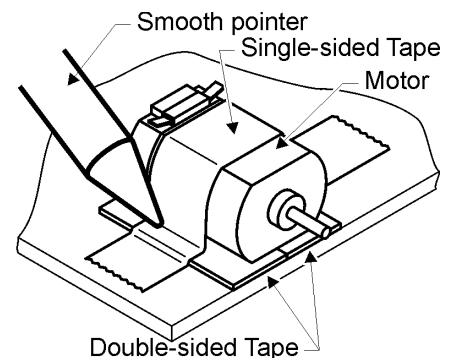

- Drill two small holes in the body: one situated just behind the motor and one at the opposite end, behind the battery holder. These holes should be along the centre line of the body.
- Thread some fishing line (about 400 mm) through the holes and tie it off, to connect the line to the body. Alternatively if using dowel for the body tie the fishing line around the dowel in the positions mentioned. You could also try using hot glue to fix the line in place.
- Suspend the plane over your finger. Adjust the plane so it is horizontal. Your finger will be at the balance point. Make a loop in the fishing line at this point.
- Take about 900mm of fishing line. Tie a loop at one end. Put the loop through the loop on the plane. Thread the line through the loop at the other end and pull it tight. Your line is now connected to the plane.
- Tie the loose end of the line to the snap swivel. The snap swivel prevents the line from twisting.
- Attach the snap swivel to an overhead point, so that the plane is suspended.

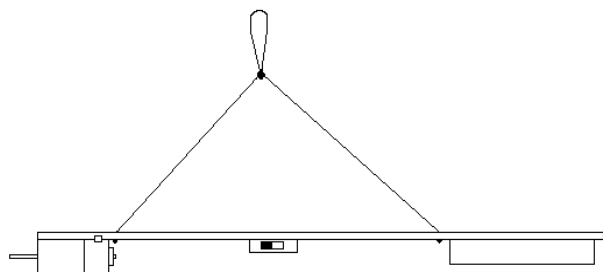

SECTION 4: WIRING UP *CAPTIVE AEROPLANE*

CONNECTING THE ELECTRICAL COMPONENTS

The Switch should be wired as shown in the "Circuit diagram".

- Connect the battery holder's red wire to one of the red wires from the switch. Twist them firmly together.

NOTE: do not put any insulation tape around any of the twisted wires at this stage.

- Connect the switch's other red wire, to the motor's red wire. Twist them firmly together.
- Twist the black wires from the motor and battery holder together.
- Insert the battery, and turn the switch on:
 - when connected correctly the propeller will spin and blow air back towards the battery.
- If the propeller spins in the correct direction, your wiring is correct - apply insulation tape over all the joined wires
- If the propeller spins in the wrong direction, you will need to swap the motor's wires:
 - remove the motor's red wire from the switch and untwist the black wires from the motor and battery holder.
 - twist the red wire from the motor to the black wire from the battery holder .
 - connect the motor's black wire to the remaining red wire on the switch.
 - twist them firmly together.
 - apply insulation tape to all the joined wires.

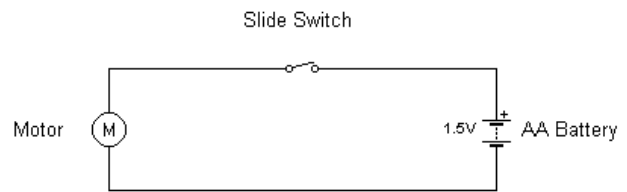

CIRCUIT DIAGRAM

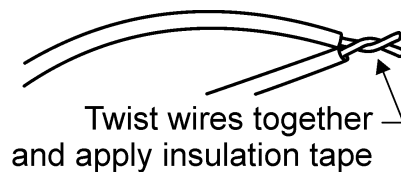

Note: this kit has components that allow this to be assembled without soldering. However, the connections will be more effective and permanent if they are soldered.

SECTION 5: USING THE *CAPTIVE AEROPLANE*

- The battery should be inserted and switched on.
- Hold the plane in your hand, pull the plane out towards the edge of the circle that it will make, and launch it carefully -a little like launching a paper plane. It should fly in a circle.

Note: With a new battery it will fly rapidly and quite high. A new alkaline battery will last around 3-4 hours.