

# LO-RIDER

## DESCRIPTION

This project requires the student to design and build a *LO-RIDER*. This basic vehicle is suitable to introduce students to Technology and Electronics. After completion of the vehicle, it can be used for a variety of experiments (physics or otherwise) or even paired with another vehicle for racing and performance tests.

This is a basic four wheeled vehicle, with both front and rear wheels on fixed axles. This vehicle:

- is capable of forward and reverse motion (direction of travel being controlled by a two-way switch)
- has a choice of two gearbox ratios (at the construction stage).

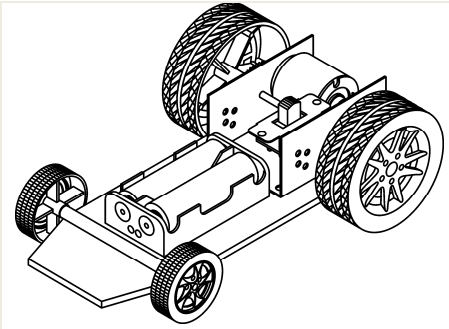

## DESIGN STAGES.

The major aspects of this project are the design, construction and assembly of the vehicle. The design stage is crucial. At this stage the location of all the components is worked out. It is best to do this by laying all of the components on a sheet of graph paper. The layout affects the minimum size and shape of the vehicle's platform, as well as the ease of assembly.

To carry out this project, a student must:

- design and fabricate the vehicle platform
- decide on the desired Gearbox ratio
- define the locations of components
- assemble the vehicle

This kit is set up with different size wheels front and back, and the gearbox mounted on the platform. At the end of this unit, are drawings showing a totally different concept using the same size wheels all round, and with the gearbox mounted below the platform. This gives a raked look, with the platform's angle being affected by the length, axle location (above or below the platform, and wheel spacing).

## 1. COMPONENTS REQUIRED

### a COMPONENTS SUPPLIED

The following components are supplied in a plastic bag, for the construction of one vehicle:

1 x	Slide Switch (Centre Off)	2 x	52 mm dia. Wheels
1 x	Battery holder (2 xAA)	2 x	38 mm dia. Wheels
1 x	2.5 mm.dia. 120mm long steel rod	2 x	Self-tapping screws 2.6mm x 4mm long
1 x	Plastic guide tube 100 mm long		

**Ix** Two Ratio Gearbox and Motor kit, consisting of:

1 x	Two Ratio Gearbox	1 x	10T Pinion gear 1.9 hole
1 x	4.5V Electric motor (round)	2 x	M2.6x 4 self-tapping Screws

### b ADDITIONAL REQUIREMENTS

- b1) The following are available from us, and need to be ordered separately: AA batteries (HD), and a 2.3mm drill bit (to drill pilot holes for the self-tapping screws)

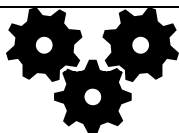

**SCORPIO TECHNOLOGY** VICTORIA PTY. LTD.

A.B.N. 34 056 661 422

17 Inverell Ave., Mt. Waverley, Vic. 3149

Tel: (03) 9802 9913 Fax: (03) 9887 8158 [www.scorpiotechnology.com.au](http://www.scorpiotechnology.com.au)

Issued: 1st April 2010

- b.2) The following material is supplied by the student / designer: fine, multi-strand electric hook-up wire (assorted colours); black PVC insulation tape; suitable adhesive (Hot Glue or double sided foam tape), material for the platform (PVC or acrylic sheet etc), and everything else!

## 2. PLATFORM

### 2.1 CHOICE OF MATERIAL

For our prototype vehicle 3 mm Plywood was used. This material was chosen as it is easily cut, shaped, drilled and glued. Balsa wood, PVA, and acrylic are some other options

### 2.2 LAYOUT

The student should make an accurate, to scale, drawing locating all the components: wheels and gearbox / motor.

### 2.3 BODY (OPTIONAL):

In addition to the basic platform, a body may be constructed for this vehicle. It might be fabricated from plastic sheet, blow moulded or carved from styrene.

## 3. REAR WHEELS

If a high torque application is required, serrations should be formed along the ends of the driven rear axle (the serrations can be formed using eg. a cold chisel; but they must be shallow).

## 4. FRONT WHEELS

The axle for the front wheels uses plastic tubing as a bearing. The plastic tubing can be fixed to the base by hot glue or double sided tape. The steel axle should be first placed through the plastic tubing, hot glue is then applied to the base. Hold each end of the steel axle and press the tubing down into the glue. Make sure that the tubing is parallel to the rear wheels, or the vehicle will travel in a circle..

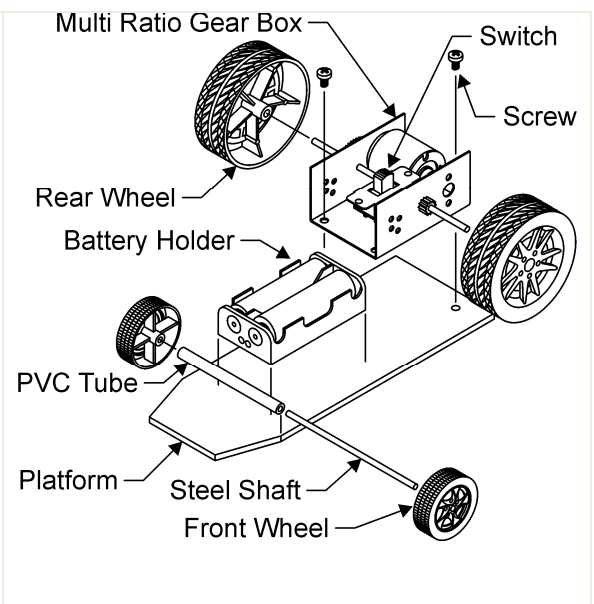

## 5. DRIVING THE REAR WHEELS

### 5.1 THE GEARBOX

A choice of 2 gearbox ratios is available, and must be chosen prior to assembly to the vehicle. The Gearbox itself is pre-assembled, and the motor needs to be assembled to the Gearbox.

The choice of ratios available at the „Output” shaft are:

Single reduction (shaft A) = 1:5

Double reduction (shaft B) = 1:25

The motor, under load, turns at approximately these speeds.

- with 3 Volts (2xAA batteries) 6,500 RPM

- with 6 Volts (4xAA batteries) 12,600 RPM

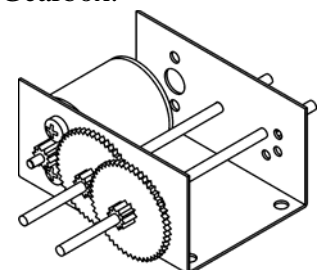

## 5.2 ASSEMBLING THE GEARBOX

Before starting assembly, the following must be done (based on the intended use of the gearbox):

- select the desired gearbox ratio – one of the two available
- cut off the other excess shaft

- Press the 10T pinion onto the motor shaft.

HINT: Place the gear on the bench, insert the motor shaft into the worm gear’s hole and gently tap the end of the shaft (where it exits the motor) with a small hammer. Stop when the worm gear is 3mm from the motor’s body.

WARNING: Don’t just push the motor down by hand as this can push the motor armature out of its bearings and jam the motor.

- Solder a suitable length of wire to each of the motor’s terminals – prior to installing the motor in the gear case.
- Secure the motor to the gearbox case using the supplied two self-tapping screws.

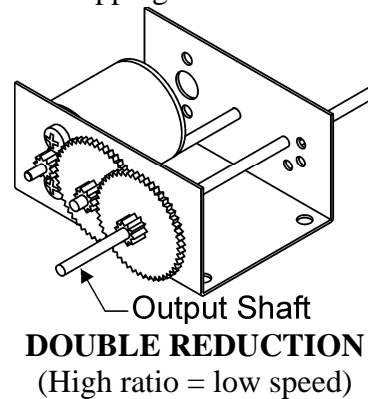
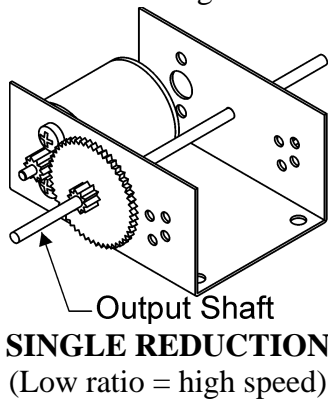

## 5.2 MOUNTING THE GEARBOX:

To hold the gearbox in place, two, 2.3 mm holes must be drilled in the platform, to match 2 diagonally opposite holes in the gear case, The self-tapping screws should be inserted from the top of the gear case to the platform. Do not over tighten the screws (refer to the drawing for mounting).

## 6. WIRING / ELECTRICAL COMPONENTS

### 6.1 ELECTRIC MOTOR

6.1.1 The electric motor is nominally 3.0 volts. This is mounted as part of the Gearbox assembly.

6.1.2 The motor can operate between 1.5 and 6 volts. The kit is supplied with a 2 x AA battery holder, which allows for 3 volts. If a different voltage is required, a different battery holder will need to be purchased. Lower voltage gives slower speed, higher voltage means higher speed.

WARNING: It is recommended not to increase the power supplied to more than 6 volts, otherwise the life expectancy of the motor may be significantly reduced.

### 6.2 THE TWO-WAY SWITCH AND BATTERY HOLDER

6.2.1 The battery holder and switch are mounted on the base. The Two-way Switch should be wired as shown in the “Wiring Schematic”. This allows forward and reverse motion of the vehicle.

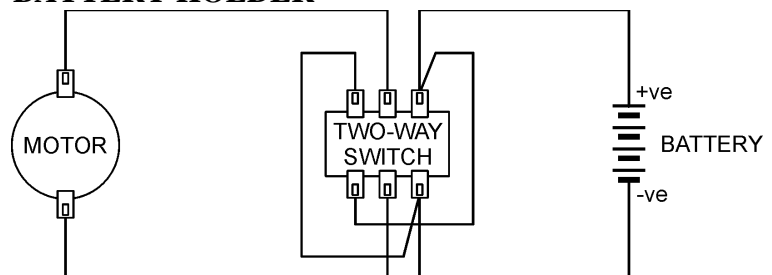

WIRING SCHEMATIC

## 7. OTHER IDEAS

The drawings we used to illustrate this teaching unit, are of the basic vehicle we made. It is up to each designer, to decide how different they want to make their own vehicle.

- We have included a couple of ideas below.

One easy option, is to make the platform longer – such as the “stretch limo” shown here

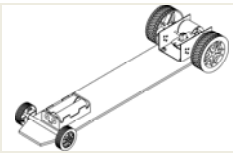

This idea is a totally different concept using the same size wheels all round, and with the gearbox mounted below the platform. This gives a raked look, with the platform's angle being affected by the platform's length, axle location (above or below the platform, and wheel spacing.

