

MARK'S MONSTER

DESCRIPTION

MARK'S MONSTER is a small agile vehicle that responds to a wired hand held controller, which is used to steer the vehicle, using two push buttons to move forwards, left or right.

MARK'S MONSTER has two independent motors and gear-drives, each controlled by its own push button switch. If both buttons are pushed simultaneously the vehicle travels forward in a straight line, but if only one push button switch is pushed the car turns in the desired direction.

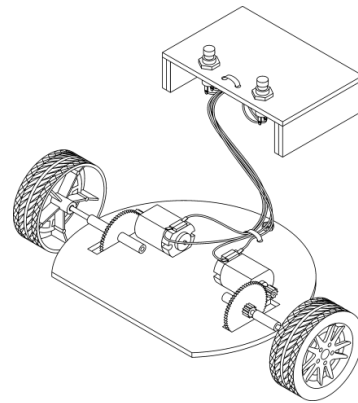

COMPONENTS REQUIRED

a) COMPONENTS SUPPLIED

The following components are supplied in a plastic bag, for the construction of one vehicle:-

1x AA Battery Compartment	1x steel rod 2.5 dia x 125mm long
2x 3 volt electric motors (flat)	1x plastic guide tube 100mm long
2x Push Button switches (Momentary)	2x 8T pinion gear (1.9mm hole)
2x 52mm wheels	2x 60Tx10T spur gear (2.4mm hole)

b) ADDITIONAL REQUIREMENTS

b1) The following are available from us, and need to be ordered separately: AA batteries, various sized gears (optional - to provide different speeds, or for use as locators), 3.5mm drill.

b.2) The following material is to be supplied by the student / designer: fine, multi-strand electric hook-up wire (assorted colours); material for the platform and for the hand held controller (PVC or acrylic sheet, MDF etc), and anything else (cable ties, tape)

Hint: we suggest a 3mm thick 200 x 100 mm board be used by the student, as a starting point. This base board will be used to cut out the vehicle's platform and switch housing / controller board.

TOOLS REQUIRED

The majority of tools required for construction of this vehicle are hand tools, eg. scroll and hand saws, a Stanley knife, small hammer, wire strippers. In addition, a soldering iron is required. A Hot glue gun and hair dryer can be useful.

Note: at various stages of construction, items need to be glued together (and sometimes removed and relocated!). We have found hot glue guns to give good results, but extreme care needs to be exercised when using hot glue as it really burns if it gets on the skin.

HINT: It is useful to have a hair dryer available during construction work. Using the hair dryer on its hottest setting will allow students to heat up the hot glue to soften it, and will allow students to reposition or remove incorrectly positioned or faulty components.

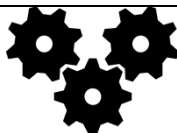

SCORPIO TECHNOLOGY VICTORIA PTY. LTD.

A.B.N. 34 056 661 422

17 Inverell Ave., Mt. Waverley, Vic. 3149

Issued 8th February 2010

Tel: (03) 9802 9913 Fax: (03) 9887 8158 www.scorpiotechnology.com.au

1. DESIGN STAGE

The major aspects of this project are the design, construction and assembly of the vehicle. The design stage is crucial. At this stage the location of all the components is worked out. It is best to do this by laying all of the components on a sheet of graph paper. The layout affects the size and shape of the vehicle's platform, as well as the ease of assembly.

1.1 PLATFORM

Note: the intended use of the vehicle should also be defined at this stage, as that also determines overall shape, additional features etc (also refer the section on Possible Applications at the end)

- The platform's design can take whatever shape is preferred. However, the student must design the platform to accommodate the two motors, axles and gears (and cut-outs /slots for the gears – if required).
- The prototype made (as shown in our sketches) had the motors inboard, with slots for the large gears. However, depending on the shape of the platform, you may put the large gear on the axle, next to the wheel. This would require a locator on the other end of the guide tube, to retain the axle (our 12T Pinion gears, with a 2.4 mm hole are suitable for this purpose)
- A small bolt may also be used for a rear support, if desired (for details refer the exploded diagram). Is this required? Or is the device stable enough without the rear support?

1.2 CONTROL UNIT

- The platform's design can take whatever shape is preferred. However, the student must design the unit to accommodate the two switches and battery holder.
- The shape, at its most basic, would be either a square or a rectangle. However, you may wish to make it a smaller version of the vehicle itself.

2. PLATFORM

2.1 CHOICE OF MATERIAL

For the prototype vehicle 3 mm Plywood was used. This material was chosen as it is easily cut, shaped, drilled and glued. Balsa wood, PVC, and acrylic are some other options (acrylics provide a choice of colours)

2.2 BODY (OPTIONAL):

In addition to the basic platform, a body may be constructed for this vehicle. It might be fabricated from plastic sheet, blow moulded or carved from styrene.

3. MECHANICAL ASSEMBLY

3.1 AXLE, WHEEL AND GEAR ASSEMBLY

- The supplied steel rod is cut to the required lengths, as 2 axles are required
- The plastic guide tube needs to be cut into pieces, with the lengths as determined by the designer (refer the isometric drawing)
- The wheels should now be assembled to the axles. This is done by GENTLY tapping the other end of the axle with a small hammer
- One length of guide tube should be slid over the axle and the Spur gear assembled to the axle.

NOTE: the gears are brittle, and should be supported. That way, the gear is not damaged when tapping the axle through the gear, with a small hammer.

Hint: Approximately one mm clearance should be allowed between the guide tube and the gear, to allow the axle to turn freely.

- The axles for the wheels use plastic tubing as both a bearing and a locator. The plastic tubing is fixed to the base by hot glue. The steel axle should be first placed through the plastic tubing, hot glue is then applied to the base. Hold each end of the steel axle and press the two parts of the tubing down into the glue. Make sure that the two axles / tubing are both in line. Be careful when you are gluing not to get any glue on the steel shaft or gear.

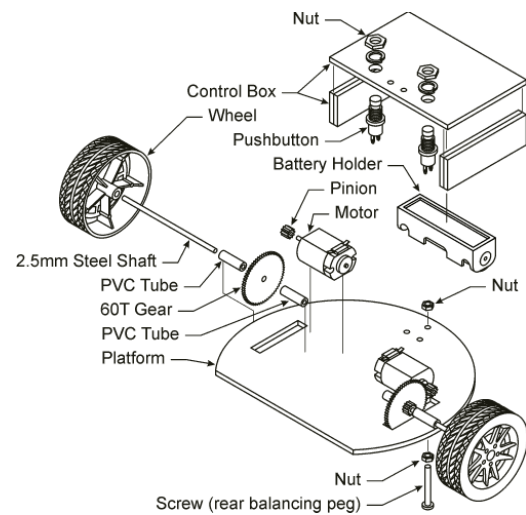

3.2 ASSEMBLING AND MOUNTING THE MOTORS

- Press the 8T pinion onto the motor shaft.
Hint: Place the gear on the bench, insert the motor shaft into the pinion gear's hole and gently tap the end of the shaft (where it exits the motor) with a small hammer. Stop when the pinion gear is level with the end of the shaft.
WARNING: Don't just push the motor down by hand as this can push the motor armature out of its bearings and jam the motor.
- Mounting the motor in place: Place a motor into position so the 2 gears mesh. Mark the position of the motor on the platform.
- Use a hot glue gun, or double sided foam tape to glue the motors onto the base. Apply the glue to the base and then press the flat side of the motor onto the glue. Repeat for the other motor, making sure axle shafts are in line with each other. Make sure the motor's terminals are facing up.
- NOTE: the motors must be placed in position so that both gears mesh (engage) properly, you will have about 30 seconds to move the motor before the glue cools (make sure that the motor is mounted parallel to the axle shaft, or the teeth will not engage properly).
- Hold the motor in place until the glue sets.

4. HAND HELD CONTROL UNIT

The last item to be made is a small hand held Control unit.

- Cut out the designed shape.
- Drill two 7 mm holes in the material to allow the mounting of the pushbutton switches. Drill two 3-3.5mm holes in the centre, towards the top, to allow a cable tie to clamp the control cable in place.
- Cut the side pieces (we used 12 x 18 mm timber).
- Glue or nail the side pieces in position along the edges so the control unit's platform is raised.

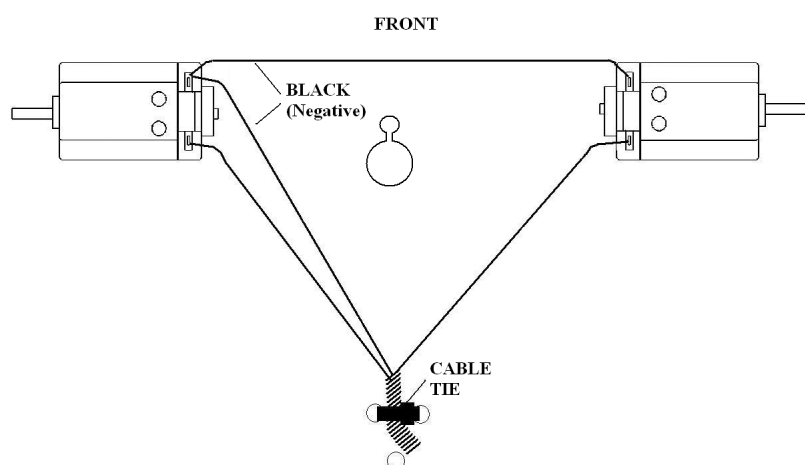

This allows the unit to be put down, without damaging the switches.

- Glue the battery holder in position under the control units platform', or inside the unit (if it will be fully enclosed). Note: the battery compartment's surface may need to be roughened with sandpaper to get the glue to stick to it.
- Fit the pushbutton switches.

5. WIRING

- Connect the wires to the motors as shown. You will need an extra wire to connect between the two motors.
- Use a small cable tie, or hot glue, to hold the cable in place.
- Cut three fine flexible wires of different colours, of the desired length - about 1 metre long works well, but you may want a longer length (what is the problem with making the wires too long?).
- Place one end of the wires into a vice or clamp them to a bench. Place the other end of the wires into the chuck of a drill (a hand powered drill, battery powered or electric drill). Operate the drill and twist the wires until they are tightly wound. Carefully release the wire from the drill chuck and carefully remove any kinks that may be present.
- Connect the red (positive) wire of the battery holder to a terminal of each of the switches.
- You will need to add an extra wire to go from one switch to the other. Then connect two of the wires to the other terminals of the switches. Connect the remaining cable wire to the black (negative) of the battery holder. Solder all the wires in place.

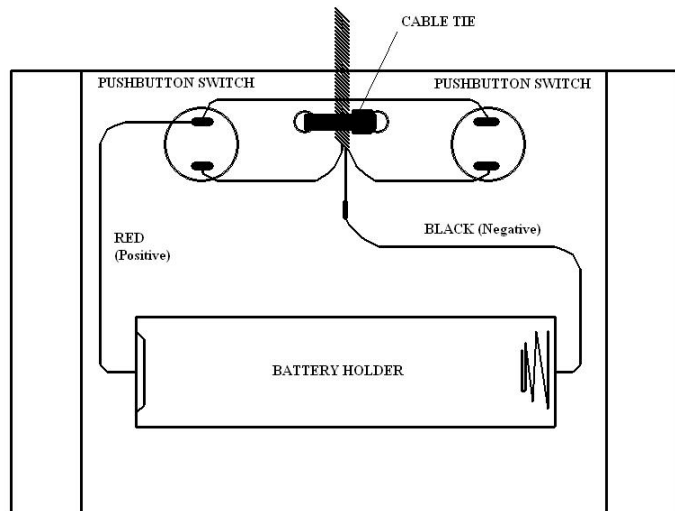

6. TESTING

Insert a AA battery into the Control unit. At this point, *MARK'S MONSTER* should be stationary.

Press the right-hand-side push button – the right hand-side wheel should turn.

Press the left-hand-side push button – the left hand-side wheel should turn.

Press both push buttons – both wheels should turn, and *MARK'S MONSTER* should go straight / forward.

That's it - *MARK'S MONSTER* is now ready for use, for battle, whatever!!

POSSIBLE APPLICATIONS

The basic design of this vehicle is quite zippy, and is fun to steer around obstacles. The design can be taken further and developed for more specific purposes. For example:

SOCCER PLAYER

- By changing the front of *MARK'Y MONSTER* to a crescent shape, a game of soccer can be played using a tennis ball.
- When the crescent shape is made some experimentation is necessary. If the crescent is made narrow and deep it is difficult to dislodge the ball from another player's control. If the crescent is too shallow then it is difficult to control the ball.

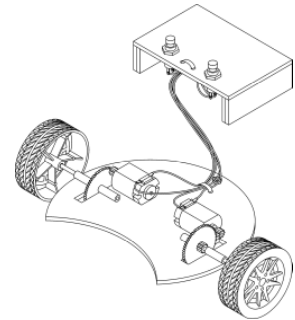

BALLOON BATTLE

- Fix a vertical plate across the front of *MARK'Y MONSTER* with a protruding spike. The front plate should have some supports to increase the plates strength.
- The spike can be made from a bamboo skewer (purchased at supermarkets). The skewer may need to be sharpened. The spikes on all competitors should be the same length. If the balloons being used have a tough skin (some helium types do) then a pin can be fixed to the end of the spike.
- Drill a 3mm hole and a 6mm hole approximately 3mm apart. Cut or file a narrow channel between the two holes (see motor wiring diagram).
- Blow up a balloon and tie off the neck of the balloon.
- Insert the neck through the large hole. Stretch the neck and slide the balloon through the narrow channel into the small hole. The balloon should now be fixed in place. Try and defeat your opponent by popping their balloon.

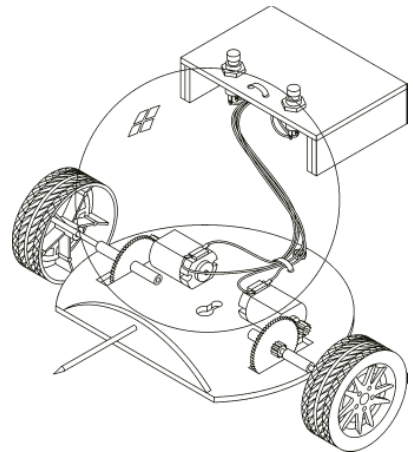

QUESTIONS / IDEAS:

- How big should the balloon be inflated?
- Should the spike be horizontal, or angled upwards, for best effect?
- Would you use a normal balloon, or a water balloon?

ROBOT WARS

- What other form of "Robot wars" can you invent??

INCREASED SPEED

If you find *MARK'Y MONSTER* is too slow, there are a couple of different ways to speed it up.

- The use of a 2AA Battery Holder will speed up *MARK'Y MONSTER*.
- The use of different gears (more teeth on the motor's pinion gear, or less teeth on the wheels spur gears), will also affect the speed of *MARK'Y MONSTER*. This provides a lot of scope for experimentation with various ratios, to see what effect this has on the device. For example, how do these changes affect controllability and speed.

Note: as *MARK'Y MONSTER* gets faster, the controllability is affected, as the speed increases the responsiveness to steering inputs.