

# ROBOBUG

## DESCRIPTION

The *ROBOBUG* is a small light sensing robot that can be controlled by shining a torch on to its sensors. When light is shone onto one of the sensors, the motor controlled by that part of the circuit starts, causing the robot to change direction. If light is shone onto both sensors the robot will move forward in a straight line. By using a torch as the light source the robot can be steered.

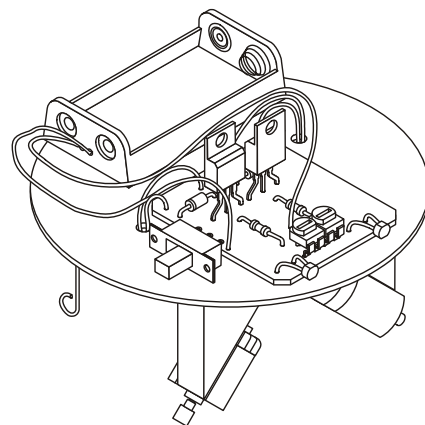

## THE PROJECT

The major aspects of this project are the planning, design, construction and assembly stages of the device.

## 1. COMPONENTS REQUIRED

### 1.1 COMPONENTS SUPPLIED

The following components are supplied in a plastic bag :

1x	Printed Circuit Board (PCB)	2x	Diodes 1N4004
2x	3V Electric Motor (flat)	2x	1K Resistors
1x	2 'AA' Battery Holder	2x	Transistors TIP122
1x	Sliding Switch (small)	2x	Light Dependant Resistors (LDR's)
1 x	14 mm long Silicon Tubing 1.3mm ID	2x	Trim pots 50 K (Variable Resistor VR1,VR2)

Note: it is suggested that, before you start construction, you check the components in the kit.

### 1.2 ADDITIONAL REQUIREMENTS

1.2.1 Available from us are AA batteries, and need to be ordered separately.

1.2.2 The additional requirements are: Material (plastic / timber) for the platform and motor mounts, fine electric wire and brass or steel wire for the balancing peg.

## 2. DESIGNING THE PLATFORM

Note: The picture shown is an example of a simple design. However, the design is not restricted to being round, and can be octagonal or any other shape desired. For example, it could take the shape of a ladybird.

- The exploded drawing in this unit shows the basic construction of the *ROBOBUG*.
- The student must design the platform so as to accommodate all of the components. These are: the Printed Circuit Board (PCB), battery holder, two motors, motor mounting blocks and the balancing peg.
- Mark the positions for all the components on the platform's design drawing. (A photocopy of this drawing can then be cut out and used as a template.)
- The motor mounts must let the motors' shafts meet the floor, preferably, at a 45 degree angle.
- Weight distribution and ease of operation should be taken into account.
- The platform should be as light as possible (plywood is a suitable material for this.)

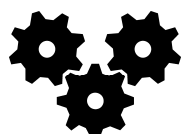

Revised: 25 May 2009

**SCORPIO TECHNOLOGY** VICTORIA PTY. LTD.

A.B.N. 34 056 661 422

17 Inverell Ave., Mt. Waverley, Vic. 3149

Tel: (03) 9802 9913 Fax: (03) 9887 8158

[www.scorpiontechnology.com.au](http://www.scorpiontechnology.com.au)

### 3. CONSTRUCTING THE PLATFORM

- Cut out the designed shape.
- Drill 2 holes in the platform to allow the wires from the PCB to pass through to both motors.
- Glue the motor mounts in position towards the front of the platform.
- Cut 7 mm of rubber tubing neatly with a sharp knife. Slide the tubing onto the motor shafts. The tubing should finish level with the ends of the shafts and provides grip, so the shafts do not spin uselessly on the ground. Make sure the tubing does not rub against the body of the motor.
- Use a hot glue gun (or other suitable adhesive) to glue the motors onto the motor mounts. Apply the glue to the motor mount and then press the flat side of the motor onto the glue. Repeat for the other motor, making sure that the platform is level.
- Make a balancing peg from thick wire and mount it at the rear. Bend the wire up where it touches the floor, so the platform is level, and the sharp point does not drag on the ground.

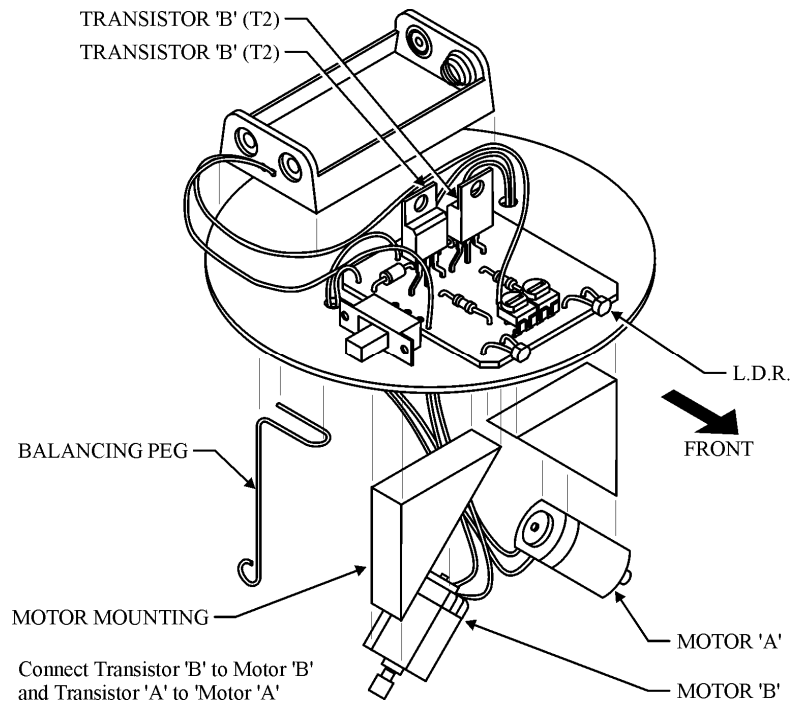

### 4. THE PCB

#### 4.1 MOUNTING COMPONENTS ONTO THE PCB

- Insert components from the non-track side of the PCB, with the leads coming out on the track side.
- Begin by mounting the resistors (R1 and R2) and Trimpots (VR1 and VR2).
- The diodes (D1 and D2) are next. Make sure the end with the white band around it is placed in the same direction as shown on the diagram below, or the *ROBOBUG* will not work.
- Transistors (T1 and T2) follow: to do this the legs must be splayed out to fit the holes. It is very important to ensure that they are mounted in the correct direction. If they are not mounted in the correct direction the transistors will be damaged when power is connected to the circuit board.

Note: On the circuit diagram T1 is shown with its metal back facing to the rear, and T2 is shown with its metal back facing to the front of the *ROBOBUG*.

- Check the circuit board against the PCB Circuit diagram. If all the components are in their correct positions they are ready to be soldered in place.

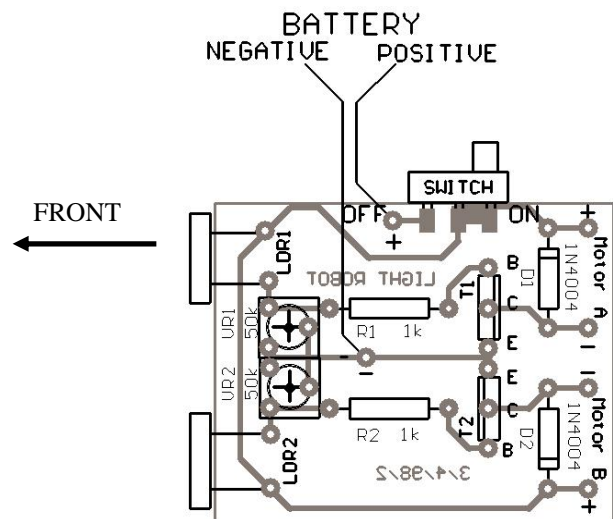

PCB CIRCUIT DIAGRAM

## 4.2 SOLDERING THE COMPONENTS IN PLACE

- Turn over the PCB and slightly bend the leads of the components outwards, to prevent them from slipping out.
- Apply the soldering iron tip to the lead and track pad at the same time. Heat the joint for 2-3 seconds and then apply the solder to the heated lead and pad on the opposite side to the soldering iron tip. Melt the solder onto the hot pad and lead, not onto the soldering iron.
- Once all the components have been soldered, use a pair of side cutters to cut off the ends of the leads as close as possible to the solder.
- Place the switch in the position shown on the diagram, with the PCB sitting between the switch terminals. Solder the terminals on the track side of the PCB into place.
- Solder the battery holder's wires in position. Note: red is positive, black is negative.
- The LDR's are placed into position last. The LDR's body needs to reach the edge of the platform. However, they should not project past the edge of the platform; otherwise they may be damaged if they are knocked. Measure the length and bend the LDR's leads 90° at that point. Insert the leads in to the holes and solder them in place.

## 5. WIRING UP THE *ROBOBUG*

- Solder two different coloured wires to the PCB; one for Motor A, and the other for Motor B.
- Feed the motor wires through the holes drilled in the platform. The wires from Motor A go to the right hand motor (when looking from in front). Motor B wires go to the left-hand motor.
- Cut the wires to length and strip about 15mm of insulation from their ends. Twist the wires together and feed the bared wire through the motor terminals; bend them so they stay in place. **DO NOT SOLDER THEM INTO POSITION YET!**

## 6. TESTING AND ADJUSTMENT

### 6.1 ADJUSTING THE *ROBOBUG*

- Before connecting the battery adjust VR1 and VR2. Do this by turning VR1 fully clockwise and VR2 fully anti-clockwise.
- Switch on the *ROBOBUG* : depending on the light conditions in the room the motors may turn. If this is so carefully turn VR1 & VR2 in opposite directions until the motors just turn off.
- Shine a light onto the sensors: the motors should turn. Check to see they spin in the correct direction and make the *ROBOBUG* move forward. If all is correct, carefully solder the wires onto the motor terminals (if not see the next section). Remember to heat the terminal and wire and melt the solder onto the hot terminal and wire.

Note: During testing try to adjust VR1&VR2 for maximum sensitivity. The motors should not turn under normal room lighting, but should operate when a torch light is shone onto the sensors.

### 6.2 TROUBLESHOOTING

- If the *ROBOBUG* moves in the wrong direction (backwards), reverse the wires to both of the motors.
- If the *ROBOBUG* spins around: one of the motors is wired in reverse: check which one and reverse the wires to it.
- If nothing happens, or you cannot adjust the motors to turn on and off: turn the switch off immediately and check all of the components. They must be in the right positions and facing in the correct direction (check against the information in the Section on assembling the PCB).

Note: If the components are correctly located and oriented check the soldering. Make sure there are no dry joints (the soldering may look dry or lumpy). Also check for short circuits, which is where solder connects across from one track to another track.

**CONGRATULATIONS! YOU CAN NOW LET *ROBOBUG* LOOSE ON THE WORLD!**