

SOCCKER 'BOT

The *SOCCKER 'BOT* is a simple electro-mechanical device that responds to a wired hand held controller, which is used to steer the device, using two push button switches to move forwards, left or right.

SOCCKER 'BOT can be used to play a game of soccer between two or more participants.

The front of the *SOCCKER 'BOT* has a “scoop” (a crescent shaped cut-out), that enables a tennis ball to be “captured” and pushed towards the goal. The scoop is shallow enough to allow a competitor to knock the tennis ball out of control, then capture the ball and try to score.

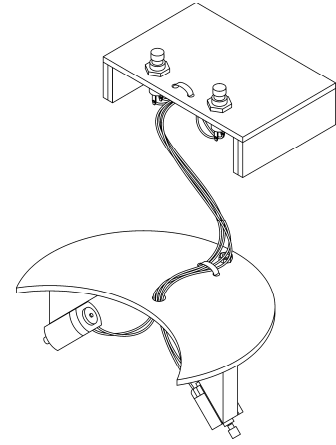

COMPONENTS & MATERIAL REQUIRED

a COMPONENTS SUPPLIED (IN THE KIT)

1 x	1x AA Battery Compartment	2 x	3Volt Electric Motor (flat)
2 x	Push-button Switch (momentary)	1 x	14 mm Rubber Tubing
1 x	M3 x 40 mm Bolt	2 x	M3 mm Nuts

b. ADDITIONAL REQUIREMENTS

b1. The following are available from us, and need to be ordered separately: AA batteries, 3.5mm drill bit

b2. The following material is to be supplied by the student / designer: fine, multi-strand electric hook-up wire (assorted colours); material for the platform and for the hand held controller (PVC or acrylic sheet, MDF etc), and anything else (cable ties, tape)

TOOLS REQUIRED

The majority of tools required for construction of this vehicle are hand tools, eg. scroll and hand saws, a Stanley knife, small hammer, wire strippers. In addition, a soldering iron is required. A Hot glue gun and hair dryer can be useful.

Note: at various stages of construction, items need to be glued together (and sometimes removed and relocated!). We have found hot glue guns to give good results, but extreme care needs to be exercised when using hot glue as it really burns if it gets on the skin.

HINT: It is useful to have a hair dryer available during construction work. Using the hair dryer on its hottest setting will allow students to heat up the hot glue to soften it, and will allow students to reposition or remove incorrectly positioned or faulty components.

1. DESIGN STAGE

GENERAL

The major aspects of this project are the design, construction and assembly of the device. The design stage is crucial. At this stage the location of all the components is worked out. It is best to do this by laying all of the components on a sheet of graph paper. The layout affects the size and shape of the device's platform, as well as the ease of assembly.

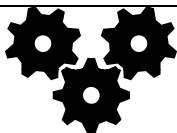

Issued: 16th February 2010

SCORPIO TECHNOLOGY VICTORIA PTY. LTD.

A.B.N. 34 056 661 422

17 Inverell Ave., Mt. Waverley, Vic. 3149

Tel: (03) 9802 9913 Fax: (03) 9887 8158

www.scorpiotechnology.com.au

There are two parts of the *SOCCKER 'BOT* to design: the *SOCCKER 'BOT* itself, and the hand held Control unit. The isometric drawing shows our prototype, but there are many other possible body shapes, and a few motor mounting options (more on this later).

1.1 MATERIAL SELECTION

The first thing to define, is the various materials for the different parts of the device. For our prototype, 3mm Plywood was used for the *SOCCKER 'BOT*'s platform and the Control unit's base. This material was chosen as it is easily cut, shaped, drilled and glued. Thin plastic sheet (PVC or acrylic etc.) could also be used. 12mm x 18mm timber was used for the sides of the control unit.

1.2 DESIGNING THE *SOCCKER 'BOT*

The student must design the platform to accommodate the two motors, motor mounting blocks and a trailing support (we used a small bolt). The design can take whatever shape is preferred, but with a scoop at the front. The scoop should be shallow enough to allow a competitor to knock the tennis ball out of the scoop, and then capture the ball.

- The picture shown is an example of one design.

The device is driven by 2 motors, and the motor mounts must allow the motors' shafts to meet the floor, at not less than a 45 degree angle.

There are 2 alternative ways to mount the motors and motor mounts:

- **DESIGN 1:** the motor mounts are mounted underneath the platform (as shown in our drawings). Thus the platform's height is approximately at the same height as the tennis ball's middle.

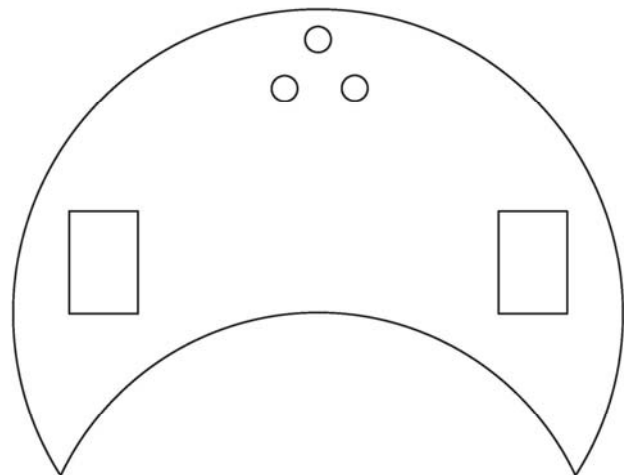

- **DESIGN 2:** the motor mounts are mounted above the platform, and the motors go down – either through or past the platform. This puts the platform quite low to the ground, and the scoop may need a vertical extension.

- If mounting the motors inboard of the platform's outside edge (ie. the motors do not extend past the platform), you will need to make cut-outs for the motors - 2 holes in the base approx. 16 x 20 mm.
- If mounting the motors outside the platform's edge, the motors will extend down and outwards, thus giving a wider and more stable device.

The device needs a 3rd "leg" to support it. A simple way to achieve this, is to drill a hole as shown at the rear of the base. This hole is for an M3mm bolt, to be locked in place with 2 nuts (as supplied). Another option is a bent wire "leg". Regardless of what is used, make sure that the platform is level.

1.3 DESIGNING THE CONTROL UNIT

The student must design the unit to accommodate the two push-button switches and battery holder. Items to consider, when designing the hand held Control unit:

- Ergonomics – it should be comfortable to hold, and easy to use the 2 push-button switches
- The simplest shape is a square or rectangle. However, the Control unit may be any size and shape desired (how about a scaled down version of the *SOCCKER 'BOT* itself?).

- Supports: our prototype used 12mm x 18mm pieces of wood to provide sides, so that, when put down, the switches were not touching the table top. However, if using an unusual shape, a couple of supports on the sides, together with the battery holder, will protect the switches

2. CONSTRUCTING THE SOCCER 'BOT

2.1 MAKING THE PLATFORM

- Cut out the platform's designed shape (a photocopy of the designed shape can be used as a template), and – if required - cut-outs for the motors.
- Drill three 3.5mm holes as shown at the rear of the base. The single hole is for a 3mm bolt, the other two holes are for a cable tie to secure the control cable in position.

2.2 ASSEMBLING THE SOCCER 'BOT

- Glue the motor mounts in position.
- Cut the rubber tubing neatly in half with a sharp knife. Slide the tubing onto the motor shafts. The tubing should finish level with the ends of the shafts and provides grip, so the shafts do not spin uselessly on the ground. Cut to length - make sure the tubing does not rub against the body of the motor.
- Glue the motors onto the motor mounts. Apply the glue to the motor mount and then press the flat side of the motor onto the glue. Repeat for the other motor, making sure that the platform is level. Make sure the motors' terminals are facing outwards (ie are accessible).
- Screw a 3mm nut, about 6 mm along the 3 mm bolt. Put the end of the bolt through the single hole at the rear of the base. Use the remaining nut to fix the bolt to the base, making sure that the platform is level.

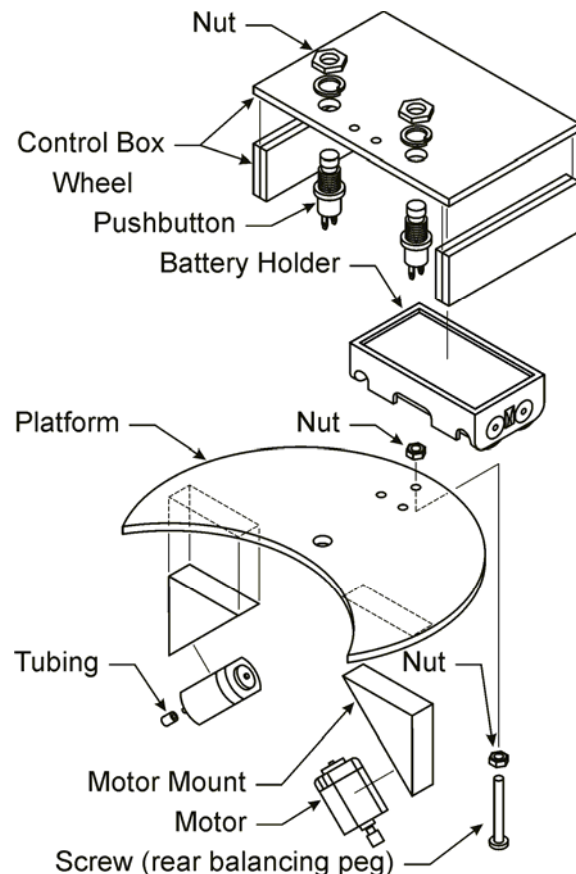

3. HAND HELD CONTROL UNIT

The last item to be made is a small hand held Control unit.

- Cut out the designed shape.
- Drill two 7 mm holes in the material to allow the mounting of the push-button switches. Drill two 3-3.5mm holes in the centre, towards the top, to allow a cable tie to clamp the control cable in place.
- Cut the side pieces (we used 12 x 18 mm timber). Glue or nail the side pieces in position along the edges so the control unit's platform is raised.
 - This allows the unit to be put down, without damaging the switches.
- Glue the battery holder in position under the control units platform, or inside the unit (if it is fully enclosed). Note: the battery compartment's surface may need to be roughened with sandpaper to get the glue to stick to it.
- Fit the push-button switches.

4. WIRING

4.1 THE WIRES BETWEEN THE CONTROL UNIT AND SOCCER 'BOT

Note: The first step is to decide the length of the wires between the Control unit and the *SOCCER 'BOT*. We suggest that about 1 metre long may be suitable – if too long, the likelihood of the wire tangling increases, while staying close to the *SOCCER 'BOT* provides better control.

- Cut three fine flexible wires of different colours, of the desired length.
- Place one end of the wires into a vice, or clamp them to a bench. Place the other end of the wires into the chuck of a drill (a hand powered drill allows good control of the speed). Operate the drill slowly, and twist the wires until they are tightly wound. Carefully release the wire from the drill chuck and carefully remove any kinks that may be present.

4.2 TO THE CONTROL UNIT

- Connect the red (positive) wire of the battery holder to a terminal of each of the push-button switches.
- You will need to add an extra wire to go from one switch to the other.
- Connect two of the wires to the other terminals of the switches.
- Connect the remaining cable wire to the black (negative) of the battery holder.
- Solder all the wires in place.

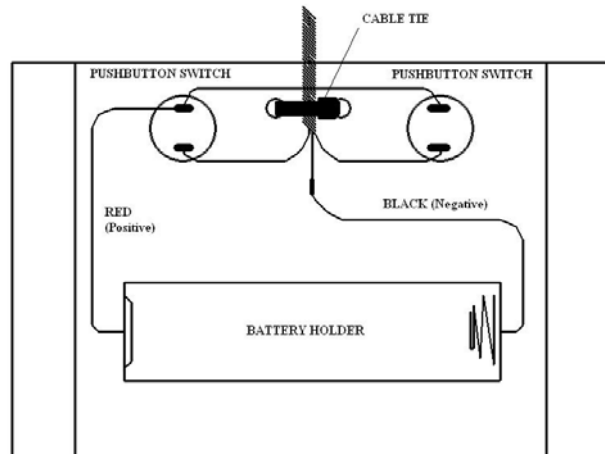

4.3 TO THE SOCCER 'BOT

- Connect the wires to the motors as shown. You will need an extra wire to connect between the two motors.

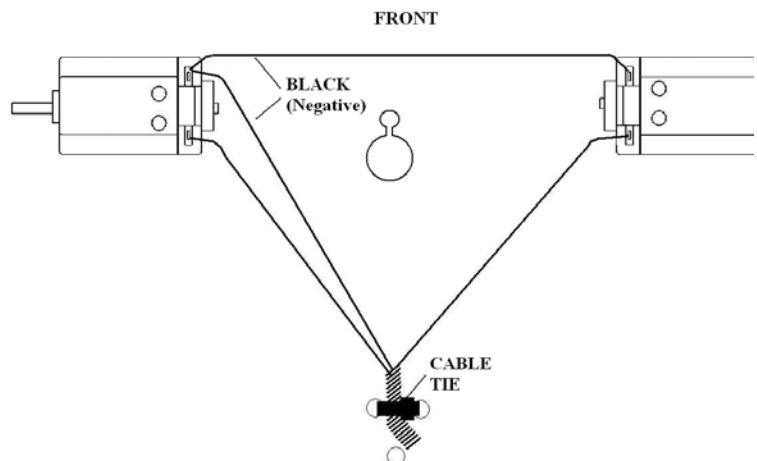

- Use a small cable tie, or hot glue, to hold the cable in place, to both the *SOCCER 'BOT* and the Control unit..

5. TESTING

Insert a AA battery into the Control unit. At this point, *SOCCER 'BOT* should be stationary.

Press the right-hand-side push button – the right hand-side motor should spin.

Press the left-hand-side push button – the left hand-side motor should spin.

Press both push buttons – both motors should spin, and *SOCCER 'BOT* should go straight / forward.

HAVE FUN, AND MAY THE BEST (*SOCCER*) *BOT* WIN!