

SOLAR PANEL POWER CONTROLLER

- MULTIPLIES THE SOLAR PANEL'S STARTING CURRENT

CONTENTS:	Section 3: Assembling the PCB & components
Section 1: General and Planning information	Section 4: Testing and Set-up
Section 2: Components and Material required	Section 5: Theory

SECTION 1: GENERAL AND PLANNING INFORMATION

Normally, powering an electric motor directly from a Solar Panel can be quite inefficient, especially during start up and at low motor speeds.

The *SOLAR PANEL POWER CONTROLLER (SPPC)* allows the motor to start and operate at a much lower light intensity than is possible with the motor directly connected to the Solar Panel.

This *SPPC* circuit holds the output of the Solar Panel at its maximum power voltage point. Thus it is able to substantially boost the starting current available to the motor. Note: this circuit regulates the input voltage rather than the output voltage.

The *SPPC* will work with any Solar Panel or combination of solar panels whose **Voltage Open Circuit (VOC) voltage is between 13 and 23 volts** (a rated 12V panel at VOC will be higher than 12V).

Energy consumption by the circuit is 0.04 W (approximately).

Note: the *SPPC's* weight is approximately 45 grams (including the Inductor).

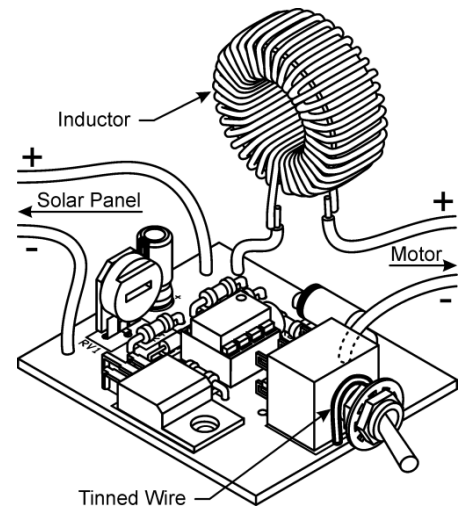

SECTION 2: COMPONENTS & MATERIAL REQUIRED

2. REQUIRED COMPONENTS

2.1 COMPONENTS SUPPLIED (IN THE KIT)

1 x Printed Circuit Board (PCB)	1 x 3.9K Resistor
1 x Zener Diode 1N751	2 x 18K Resistors
1 x 8 Pin IC Socket	1 x 180K Resistor
1 x 47 μ F 25 VW Capacitor	1 x 6.8K Resistor
1 x 47pF 100 V Capacitor	1 x 10K Trimpot - Horizontal
1 x Semiconductor (IC) TL071	1 x SPDT Toggle Switch (2 position)
1 x Semiconductor (Mosfet) MTP3055	1 x 100 μ H 5 Amp Inductor
1 x Semiconductor (Diode) SR340	

2.2 ADDITIONAL REQUIREMENTS

Red and Black Electric wire (14 strands of 0.2mm diameter wire), 1mm tinned copper wire, solder, soldering equipment, side cutters, insulated needle nose pliers, current meter, 1.0 to 2.7 ohm 10 watt resistor, (for use in testing and set-up)

Note: it is suggested that, before you commence construction, you check the components supplied in your kit, and ensure that you have everything required.



SCORPIO TECHNOLOGY VICTORIA PTY. LTD.

A.B.N. 34 056 661 422

17 Inverell Ave., Mt. Waverley, Vic. 3149

Rev'd: 23 September 2011

Tel: (03) 9802 9913 Fax: (03) 9887 8158 www.scorpiotechnology.com.au

SECTION 3: ASSEMBLING THE PCB & COMPONENTS

COMPONENTS FOR MOUNTING ON THE PCB

All the components supplied have to be assembled onto the PCB, with the exception of the 100µH 5 Amp Inductor. The components have to be soldered onto the PCB in the positions as listed in brackets:

1 x Zener Diode 1N751 (Z1)	1 x Transistor (Mosfet) MTP3055 (Q1)
1 x 47µF 25 VW Capacitor (C1)	1 x Diode SR340 (D1)
1 x 47pF 100 V Capacitor (C2)	1 x 10K Trimpot - Horizontal (RV1)
1 x 8 Pin IC Socket & IC TL071 (IC1)	1 x SPDT Toggle Switch (Bypass) (S1)
1 x 3.9K Resistor (R1)	Colour bands: Orange, White, Red
2 x 18K Resistors (R2, R5)	Colour bands: Brown, Grey, Orange
1 x 180K Resistor (R3)	Colour bands: Brown, Grey, Yellow
1 x 6.8K Resistor (R4)	Colour bands: Blue, Gray, Red

3.1 MOUNTING COMPONENTS ONTO THE PCB

NOTE: The assembly of the components should be carried out before soldering the components in place. Begin with the components that sit lowest on the PCB.

- Mount the resistors** in place. Resistors are non-polarised components and do not need to be placed in any particular direction. However, the convention is that horizontal resistors are mounted with the gold band to the right and vertical resistors to the bottom.
- Make sure when mounting the **zener diode Z1** and **semiconductor D1** that the negative end (the one with the band) is mounted in the same direction as shown on the PCB

Inductor (L1) is only used if the motor inductance is less than 80uH or is unknown

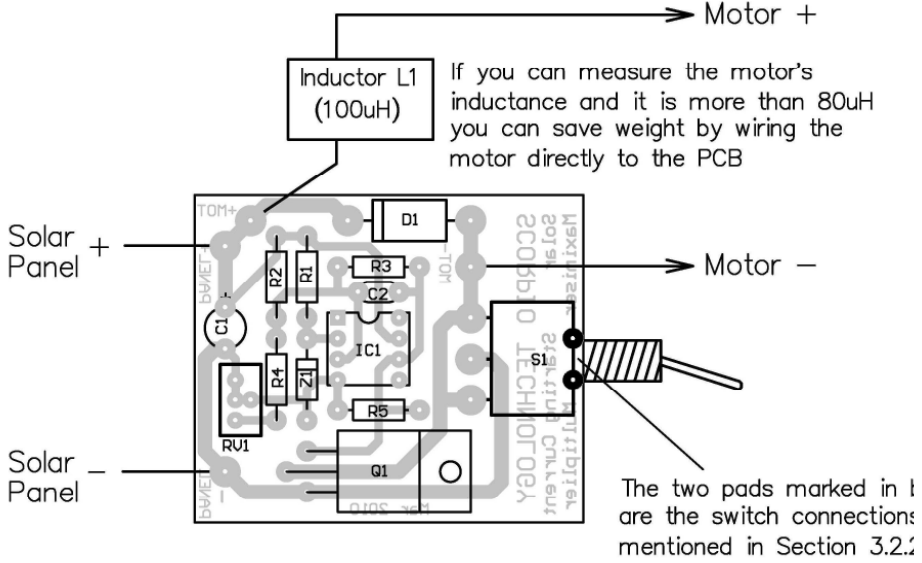

WARNING: These components (Z1 and D1) must be connected the correct way for the PCB to work.

- The IC socket is mounted** next: make sure that the notch on the socket faces in the same direction as indicated on the PCB
- Mount **the 10K trimpot** (identified as "103: on the Trimpot) in place.
- The **two capacitors** are mounted next.
 - The **47µF Electrolytic capacitor** is polarised: that is, it has positive and negative leads. It must be connected the correct way for the PCB to work. The positive and negative leads can be identified by two methods: (1) the stripe on the body of the capacitor marks the negative lead, and (2) the long lead is positive. Refer to the PCB to determine the position of the leads.

- The **47pF disc ceramic capacitor** is not polarised and can be mounted in either direction, but it is preferable to mount it with the printed value visible (i.e. facing you).
- The **MTP3055 power semiconductor (Mosfet)** is mounted next.

WARNINGS:

- *The Mosfet can be damaged by static electricity. Before handling the Mosfet you will need to discharge any static electricity built up in your body. To do this you need to briefly touch the metal case of an earthed appliance.*
- *The Mosfet MUST be mounted facing in the correct direction or it will be damaged when the PCB is connected to the Solar Cell.*

Using a pair of insulated pointy nosed pliers bend the centre lead out, about 3mm from the two outside leads. Position the leads in their holes so that the metal back is facing towards the Mosfet's picture on the PCB. Press on the plastic section of the Mosfet and carefully bend it down on to the PCB.

3.2 SOLDERING THE COMPONENTS IN PLACE

NOTE: Check that all the components are in their correct positions: it pays to spend some time doing this before soldering components in place. It can prevent wasted time later on, trying to find out why the circuit is not working and unsoldering and replacing damaged or wrongly positioned components.

3.2.1 GENERAL PRINCIPLES

- Turn over the PCB and slightly bend the leads of the components outwards, to prevent them slipping out
- Apply the soldering iron's tip to the lead and track pad at the same time. Heat the joint for 2-3 seconds and then apply the solder to the heated lead and pad on the opposite side to the soldering iron tip. Melt the solder onto the hot pad and lead, not onto the soldering iron.
- Once all the components have been soldered, use a pair of side cutters to cut off the ends of the leads – as close as possible to the solder

3.2.2 FURTHER ASSEMBLY

- After all the soldering has been completed, **insert the TL071 I.C.** in its place in the socket. Ensure the notch on the end faces in the same direction as on the socket. Check that the legs line up with the I.C. sockets holes and press down firmly with your thumb.

Note: it may be necessary to push the legs of the I.C. together slightly to line them up with the socket holes.

THE BYPASS SWITCH'S CIRCUIT

- To install the **Bypass (Toggle) Switch** you will need to:
 - solder 2 pieces of 1mm wire (about 20mm long) to one of the switch's centre terminals, and one of the end terminals - along one side of the switch (this means that 2 adjacent terminals have wires connected).
 - Insert the wires into the holes on the PCB.
 - Make sure that the switch sits flat on the PCB, in the position shown on the PCB.
 - Solder the wires into their holes on the PCB.

MOUNTING THE BYPASS SWITCH

Note: if not supplied separate from the switch, remove the washer and nut from the toggle switch.

- Use another piece of tinned 1mm wire (about 30mm long) and bend it into a U shape around a 7mm drill.
- Place the wire over the neck of the switch and insert it into the two holes on the edge of the PCB, directly under the neck of the switch.
- Pull the wire down so it sits snugly around the neck of the switch.
- Solder the ends of the wire into position.
- Place the large flat washer on the switch. Screw the nut up against the washer and tighten it in place.

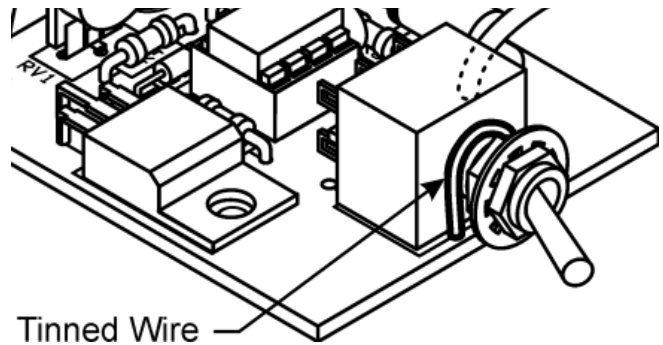

Note: this is to hold the switch firmly in place and prevent undue stress on the switch wires when the switch is operated.

CONNECTING THE *SPPC* TO THE SOLAR PANEL, MOTOR AND INDUCTOR

- **Hook up wire** (14 strands of 0.2mm diameter wire) can now be soldered to the PCB to connect it to the solar panel and the motor. Try and keep the wires as short as reasonably possible.
HINT: Make sure you use Red wire for Positive and Black for Negative.
- **The 100 μ H Inductor (L1)** is not mounted on the PCB. L1 must be used if the motor connected to the *SPPC* has an inductance of less than 80 μ H, or its inductance is unknown.
 - If the Inductor is required, it is connected between the PCB and the motor. This can be carried out in one of 2 ways: (1) using 2 short wires, one from the PCB to one of the inductor's legs, and the second from the other leg to the motor (2) by soldering one of the inductor's legs into the PCB mounting hole, and using a wire from the other leg to the motor.
Note: it isn't important which motor terminal the Inductor is connected to.
 - If the Inductor is not required, the PCB and the motor are connected by one wire.

SECTION 4: TESTING AND SETUP

LIGHT SOURCE:

When testing, different light sources could be used to provide light to the solar panel. The easiest two to use are:

- The sun. This is a variable light source, and to know what sunlight intensity is available – the easiest way is to use a calibrated solar panel to measure the sunlights intensity (our #10 panel is useful for this)
- A flood light – a halogen light of 500 watts is a cheap option. If you use such a lamp directly facing the panel and about 300mm away, you can expect light equivalent to about 50% sun. CAUTION: the lamp puts out more heat than the sun, so only illuminate the panel for about 40 seconds – then allow the panel to cool down.

WARNING: Insufficient lighting or low intensity sunlight can be misleading – it can produce enough power to operate the *SPPC*, but not enough power to drive a solar car.

COMMENT: when testing the *SPPC*, the only way to check that it works, is by using a meter (as detailed below) – that will show the increased performance when the *SPPC* works.

MEASURING THE OUTPUT

NOTE: ALL tests should be performed at the same solar panel illumination level.

- Connect the solar panel to the PCB, making sure that positive (+) and negative (-) go in their correct positions. Use some plastic tape wrapped around the motor shaft to prevent it from turning.
- Use a current meter set to the 10 Amp DC range and connect it in series with the motor.
 - If a current meter is not available, use a 0.51Ω 5 watt resistor in series with the motor. Then use a voltmeter to read the voltage produced across the resistor by the motor current, the 2 Volt setting should be suitable.
- Expose the solar panel to your chosen light source. Adjust RV1 on the PCB to obtain a maximum reading on the meter. **Do not expose the solar panel for more than 30 seconds at a time because the motor rotor winding may overheat.** Wait about 5 minutes to let the motor cool down before repeating or checking the setting.
- The preferred method, if you wish to avoid the possibility of overheating the motor, is to substitute a 10 watt 1 to 2.7 Ohm resistor in place of the motor. A voltmeter can then be connected directly across the resistor and used to obtain the maximum reading.

WARNING: Do not attempt to connect the SOLAR PANEL POWER CONTROLLER to a standard power supply under any circumstances. Damage to the Mosfet will occur very quickly.

HINT: The maximum power voltage point of a solar panel changes with both the temperature of the solar panel and the sun's intensity. You may wish to make adjustments under various conditions to obtain the best compromise.

SECTION 5: THEORY: -

HOW THE SOLAR PANEL POWER CONTROLLER (SPPC) MULTIPLIES STARTING CURRENT FOR AN ELECTRIC MOTOR POWERED BY A SOLAR PANEL

5.1 INTRODUCTION

Powering an electric motor directly from a solar panel, can be quite inefficient, especially during startup and at low motor speeds. This is because the resistance of a stationary motor is low and the maximum amount of current available from the solar panel is limited.

However, by electronically holding the output of the solar panel at the maximum power voltage point, the circuit described here is able to substantially boost the starting current available to the motor. To understand the operation of the circuit, some of the characteristics of electric motors and solar panels need to be understood. In essence, the circuit is a switch mode voltage down converter where the input voltage, rather than the output voltage is regulated. This can be better understood by examining the type of load that a motor presents to a solar panel and how the solar panel reacts to this load.

5.2 ELECTRIC MOTOR CHARACTERISTICS

When an electric motor (with no mechanical load applied) is powered by a constant voltage power source (e.g. a battery), the resulting current will be small. As the mechanical load on the motor is increased (by holding the shaft for example), the current will increase and the motor will slow down in proportion to the amount of load applied. When the mechanical load is released, the motor speeds up again and the current decreases to the value necessary to just overcome the losses inside the motor (such as brush friction) – these losses are called “no load current”.

In other words, the electrical load resistance that a motor presents to the power source is low when stalled (equivalent to the DC rotor resistance) and high (perhaps over 20 times the DC rotor resistance) when operating at maximum speed with no mechanical load applied.

5.3 SOLAR PANEL CHARACTERISTICS

When the surface of the cells of a solar panel is exposed to the sun, a small voltage of approximately 0.6 volts is developed across each cell. This means that the voltage generated by a panel of 24 cells when connected in series is about 14 volts, while a panel of 36 cells will have about 21 volts. This is sometimes called the 'no load' or 'open circuit' output voltage, and is usually referred to as VOC (Volts Open Circuit).

Placing a current meter across the output terminals of the panel will decrease the voltage to almost zero.

The resulting 'short circuit' current is directly proportional to the intensity of the sunlight reaching the panel and is usually

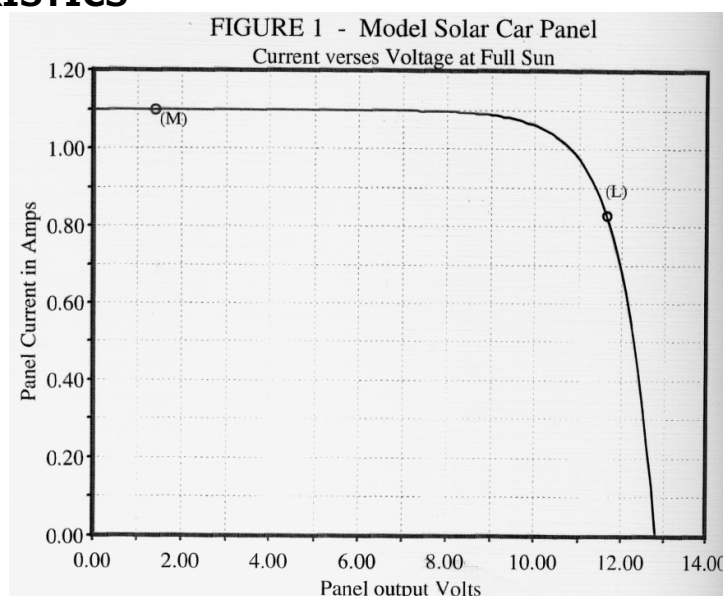

referred to as ISC (where the I is the symbol for current and the SC stands for 'Short Circuit'). The maximum value of ISC is obtainable when the panel is positioned at right angles to the sun.

The performance of a solar panel depends on the type of load connected to it. Refer to the *Current versus Voltage* graph of an 11 watt solar panel containing 22 cells shown in *Figure 1*. A lamp with a resistance of about 13 ohms will operate at point 'L' on the graph, while a stalled motor with an armature resistance of 1.2 ohms will position itself at point 'M'.

Power (in watts) is calculated by multiplying the voltage across the load by the current through the load. The result of converting the *Current versus Voltage* graph of *Figure 1* to a *Power versus Voltage* graph is shown in *Figure 2*, where the maximum power point occurs when the panel voltage is about 10.8 volts.

Note that point 'M' (representing a stalled motor) is well below the graph's maximum point, while point 'L' is very close to it. This clearly indicates that the efficiency of a solar panel connected to a stalled motor is far from ideal. Indeed, the power supplied to the stalled motor is less than two watts, while the power supplied to the lamp with a load resistance more than 10 times higher, is over 9 watts.

5.4 Electronic Motor Starting Current Multiplier

FIGURE 2 - Model Solar Car Panel
Power versus Voltage at Full Sun

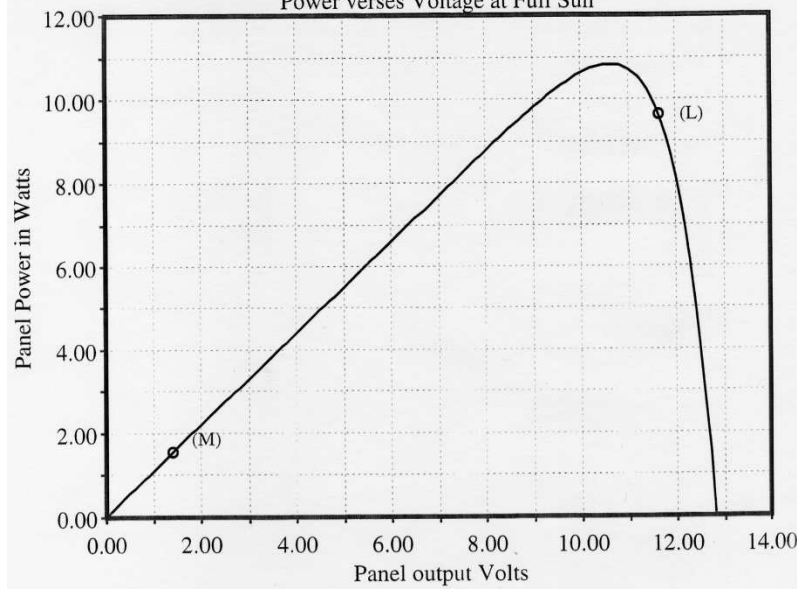

Figure 2 shows that when the electrical load placed across the solar panel allows a voltage of 10.8 volts to be developed, maximum power will be extracted. This is exactly what this Motor Starting Current Multiplier circuit does. As long as the load resistance of the motor remains below the optimum electrical load of the solar

panel, the circuit will transfer the maximum power to the motor. This means that at start up, when the effective electrical load is only the armature resistance, the output current to the motor can be over three times the input current from the solar panel.

5.5 Circuit Description

Refer to the full circuit diagram of the unit in *Figure 3*. Assume that the voltage across C1 is zero and Q1 is turned off. When the solar panel is exposed to the sun the panel current will start to charge C1. Nothing more happens until the voltage across C1 exceeds the breakdown voltage of Z1, and holds the voltage on the inverting input (pin 2) of IC1 at about 5 volts. At this time the voltage at the non-inverting input (pin 3) of IC1 is held well below 5 volts by the voltage divider action of R2, R4 and RV1. This leaves the output of IC1 (pin 6) close to zero, and prevents Q1 from conducting.

When the voltage across C1 reaches 11.0 volts, the voltage through the voltage divider on pin 3 of IC1 rises to 5 volts. This causes the output of IC1 (pin 6) to rise and apply more voltage to pin 3 via R3; pin 6 then rapidly rises to over 8 volts and turns on Q1. Current can now start to flow through the motor from C1 via the conduction of Q1.

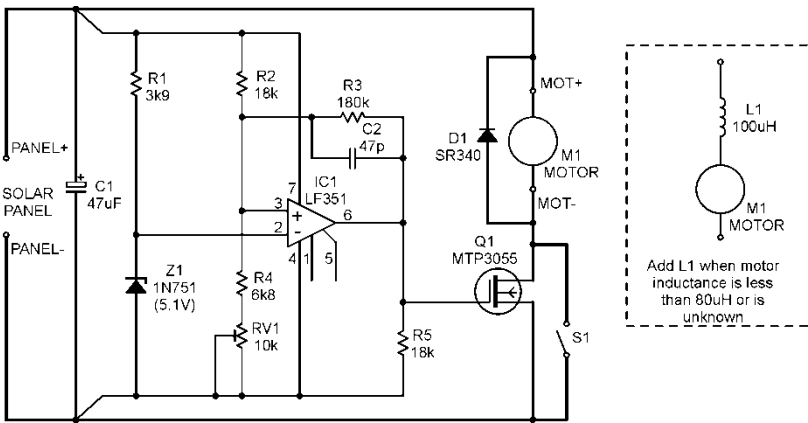

Figure 3

drop the voltage at pin 3 even further. This will cause pin 6 to drop very rapidly and quickly turn off Q1.

The difference between the turn on and turn off voltage is about one volt. This is controlled by the value of R3, where a higher value will decrease the difference voltage and a lower value will increase the difference voltage.

With Q1 turned off, the inductance of the motor will force the current to continue to flow and turn on diode D1. At the same time the panel current will charge C1 towards 11.0 volts, and again turn on Q1 when the voltage across C1 reaches 11.0 volts. It does this regardless of the current that may still be circulating around the motor and D1. In this way it is possible for the motor current to be many times the solar panel current, because the conduction of Q1 is controlled by the voltage across C1 and is independent of the amount of the motor current. In turn the voltage across C1 depends on the current available from the solar panel and the turn on/off points of Q1.

In practice, the solar panel voltage can exceed 11.0 volts. This will occur at high motor speeds when Q1 is held conducting all the time because the motor current is not high enough to decrease the voltage across C1. At this time the equivalent electrical load resistance of the motor, is higher than the solar panel optimum electrical load required for maximum power. When this occurs, Q1 simply acts as a low loss switch between the solar panel and the motor.

C2 is included across R3 to compensate for the capacitance at the non inverting input of IC1. It assures positive switching operation when the panel current is maximum. R5 is included across the gate and source of Q1 to prevent stray electrostatic voltages forming and causing Q1 to conduct. This can happen when the voltage across C1 and IC1 is less than 3 volts and normal output operation of IC1 ceases. Under these conditions the output (pin 6) of IC1 becomes a high impedance and could prevent any stray gate to the source voltage from bleeding away.

The efficiency of this power converter with the motor at zero speed is about 80%, depending on the armature resistance of the motor. This increases to over 98% as the motor voltage approaches or exceeds the maximum power voltage of the solar panel. Most of the power loss at low motor speeds is dissipated in D1, Q1 and C1, while a lesser amount is absorbed by the resistance of the inductor and other circuit components. At high speeds, the on resistance of Q1 and the resistance of the inductor account for most of the power loss.

If needed to comply with race regulations: to totally discharge capacitor C1 move the bypass switch (S1) to either side of its centre position and completely cover the solar panel for a few seconds.

However, the rate of rise of the motor current is restricted by the inductance of the motor and the series inductor, but after a short period of time (depending on the inductance value), the motor current will exceed the panel current, and cause the voltage across C1 to decrease.

When the voltage across C1 decreases to about 10.0 volts, the voltage at pin 3 will go below 5 volts and cause pin 6 of IC1 to start to fall, and because of R3,

