

WALKIE TALKIE

DESCRIPTIONThe *WALKIE TALKIE* is a transceiver, which means that it transmits and receives. The *WALKIE TALKIE* transmits on a frequency of 27.145 Megahertz on the FM band. As well as transmitting and receiving speech, the *WALKIE TALKIE* can be used to transmit and receive Morse code. Its communication distance over open ground is approximately 100 metres.

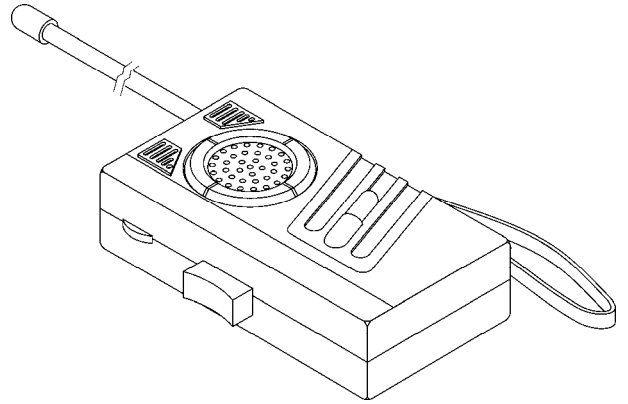

INVESTIGATION

This project provides a number of topics suitable for students to investigate. Some ideas are listed below.

Note: This *WALKIE TALKIE* operates on the FM band, as do many commercial radio stations.

Other commercial stations operate on the AM band.

- What is Frequency Modulation (FM)?
- What is Amplitude Modulation (AM)?
- What is the difference between AM and FM.(How are they transmitted and received?)
- What advantages and disadvantages do each have, when compared to each other? How does this translate into reality – in other words, what styles of radio have developed on AM and FM?
- Which types of transmission are used, and for what purpose are they used in television?
- How is FM stereo transmission achieved?
- When and by whom were the first AM and FM transmissions made?
- How does an antenna work? What process is used to convert radio waves to electrical energy?
- How does a speaker work?
- How does a moving coil microphone work?

THE PROJECT

The major aspects of this project are the planning, component identification, assembly, testing and evaluation.

PLANNING STAGE

Before commencing work the student should spend some time planning the project. The student should draw up a plan describing:

- the sequence of work that will be necessary to complete the *WALKIE TALKIE*. This could be incorporated into a timeline showing the anticipated completion dates of each section of work. The student can then use the timeline to properly manage classroom time.
- How the *WALKIE TALKIE* operates (principles / function)

These plans should also take into account what items should be recorded throughout the life of the project. These could include, maintaining a Log Book :-

- Recording progress on a weekly or daily basis.
- Detailed information about problems encountered, measurements taken and observations made. These should be used in the evaluation process.
- Assessment on progress in relation to the (projected) timeline.

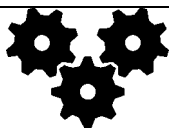

Revised: 20th July 2008

SCORPIO TECHNOLOGY VICTORIA PTY. LTD.

A.B.N. 34 056 661 422

17 Inverell Ave., Mt. Waverley, Vic. 3149

Tel: (03) 9802 9913 Fax: (03) 9887 8158

www.scorpiontechnology.com.au

WALKIE TALKIE Teaching unit

In addition, at this stage the teacher and student should pose a number of questions before commencing the project. These questions should be used, by the student, to evaluate the project after its completion.

1. COMPONENTS SUPPLIED

1 x	P.C.B		
1 x	10 Ω Resistor	R10 – Br/Bk/Bk	2x 82 Ω Resistor R1, R12 – Gy/R/Bk
1 x	100 Ω Resistor	R5 – Br/Bk/Br	2 x 680 Ω Resistors R11, R13 – Bl/Gy/Br
1 x	3.3 K Ω Resistor	R9 – O/O/R	1 x 5.6 K Ω Resistor R2 – Gr/Bl/R
1 x	8.2 K Ω Resistor	R8 – Gy/R/R	2 x 18 K Ω Resistors R3, R6 – Br/Gy/O
1 x	27 K Ω Resistor	R4 – R/V/O	1 x 470 K Ω Resistor R7 – Y/V/Y

(Abbreviations: Br=Brown; Bk=Black; Gr=Green; Gy=Grey; R=Red; Bl=Blue; O=Orange; V=Violet; Y=Yellow)

1 x	5pF Disc Ceramic	(5) C6, C13	2 x 10pF Disc Ceramic	(10) C16
1 x	27pF Disc Ceramic	(27) C5	1 x 50pF Disc Ceramic	(50) C2
1 x	20 (or 22)pF Disc Ceramic	(20 or 22) C1	1 x 3.3nF Greencap	(332) C19
1 x	5nF Disc Ceramic	(502) C4	2 x 20nF Disc Ceramic	(203) C10, C18
1 x	40Pf Disc Ceramic	(40) C12	4 x 40nF Disc Ceramic	(403) C7, C8, C9, C11

NOTE : There is no C3 or C17 (ref. 3.2)

Note: The numbers shown in brackets are the coding marked on the Disc Ceramic Capacitors

2 x	100 μ F Electrolytic capacitors	C14, C15	1 x	RF Variable Transformer	T1
1 x	2SC1417 Transistor	T1	1 x	Transformer	T2
3 x	9014C Transistor	T2, T3, T4	1 x	Inductor	L1
1 x	Push Switch - Switch 1		1 x	Battery Clip	
1 x	Antenna and Plastic Cap		2 x	Lugs	
3 x	Tinned Copper Wire Links		5 x	Self Tapping Screws	
1 x	5K Potentiometer (volume control)		3 x	Rivets (1 long, 2 short)	
1 x	Small Self Tapping Screw – disc to 5K Pot.		1 x	22 mm Disc - Volume Control wheel	
1 x	Speaker		5 x	Wires with tinned leads	
1 x	Plastic Button - to fit Push Switch		1 x	Transceiver Sticker	
1 set	Outer Casing (Top, Lower, Battery Cover, Black “Signal” Cover), Red “Signal” Button				
1 x	Carry Strap.				

Note: Check the components in your kit against the list – ensure that you have ALL components before you commence.

2. OVERVIEW: HOW THE *WALKIE TALKIE* OPERATES

2.1 TRANSMISSION

Sound waves hitting the microphone are converted to an electrical waveform. The waveform is sent to the pre-amplifier, where its amplitude is increased to a useable size. The power amplifier then amplifies the waveform further. The amplified waveform is then modulated by the oscillator, to have a transmission frequency of 27.145 MHz. The signal is transmitted through the antenna.

2.2 RECEPTION

The antenna picks up the radio waves. This produces a very weak electrical signal, by electromagnetic induction. This very weak signal is detected and demodulated into a very weak audio frequency. This is amplified by the pre-amplifier to a useable size. The power amplifier is used to produce a large enough waveform to drive the speaker. The speaker converts the electrical signal to sound energy that you can hear.

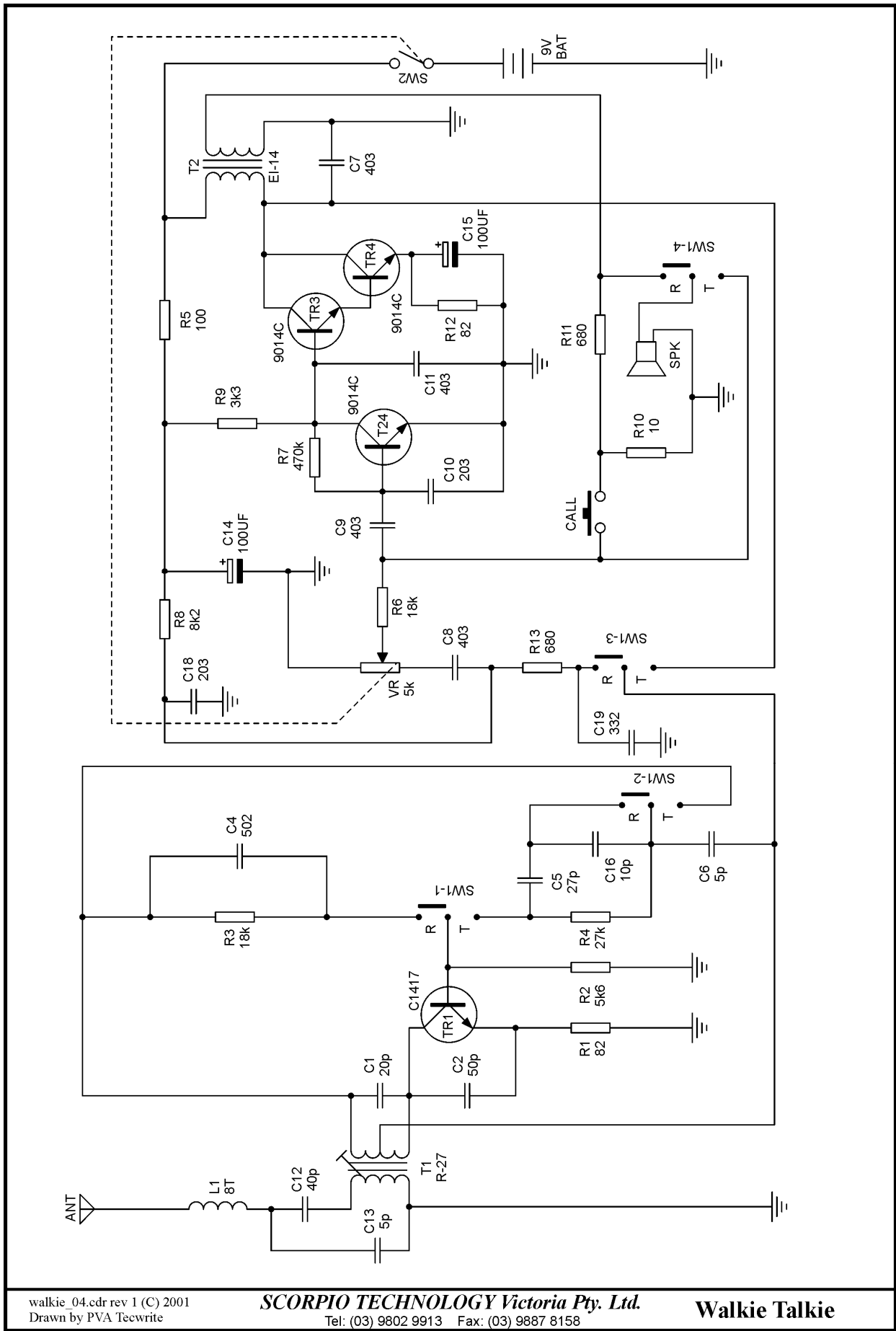

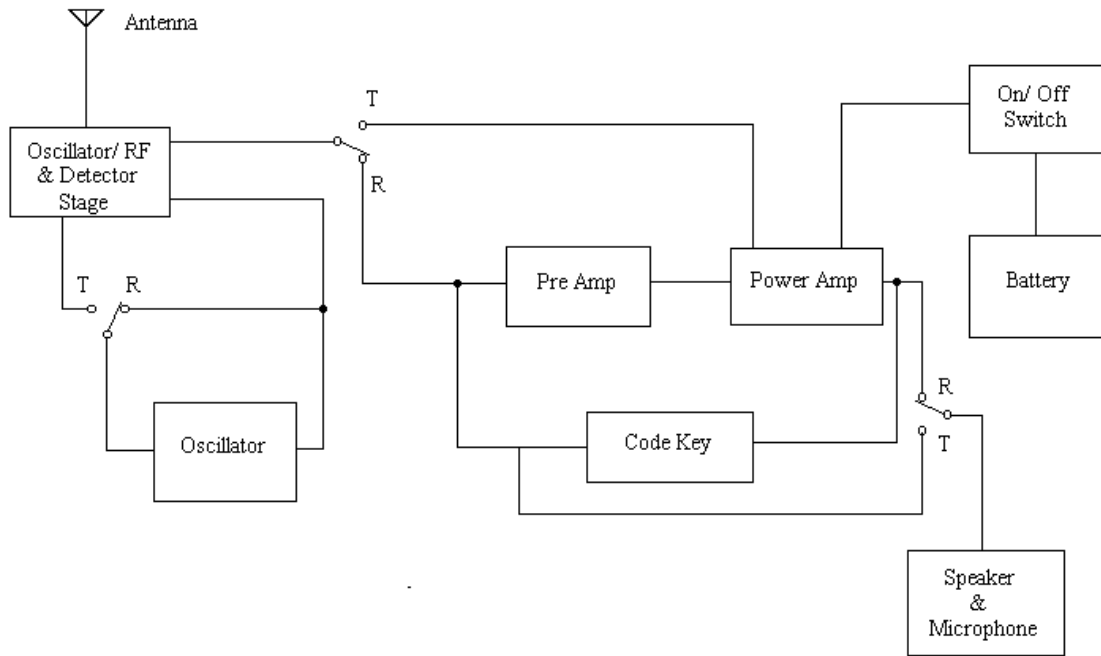

Note The microphone and the speaker operate in the same way. A speaker can not only convert electrical energy to sound, but can also convert sound energy to electrical energy.

3. THE PRINTED CIRCUIT BOARD

3.1 GENERAL INFORMATION

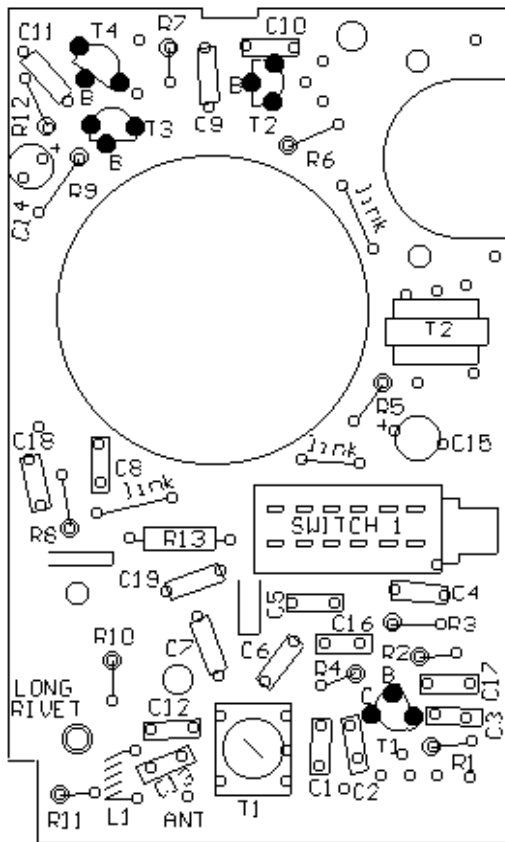

in position. (Don't bend the leads too far or you will have considerable trouble removing them - if it becomes necessary later on.)

If you are experienced at assembly, testing and fault finding of P.C.B.'s, you may wish to assemble all the components and then proceed. Otherwise, refer to section 3.2 for a progressive method. However, the following information is worth reading regardless of experience.

The location of the components is as printed on the P.C.B.. The copper tracks are on the underside of the P.C.B.. The outline of the tracks is visible through the P.C.B.. These will act as a guide, to help locate the components onto the P.C.B.. Care must be taken when installing components, as some are polarized (ie. they must be orientated in the correct direction), while others are non-polarized (ie. they may be fitted in either direction).

At every stage of the assembly process, care must be taken to ensure that each component's polarity is correct – i.e. that it is in the correct position and facing in the direction shown on the PCB.

Once all the components are correctly located, turn the circuit board over and bend the component leads outwards, away from the component's body (about 15 degrees from vertical). This will prevent the component from slipping down while being soldered

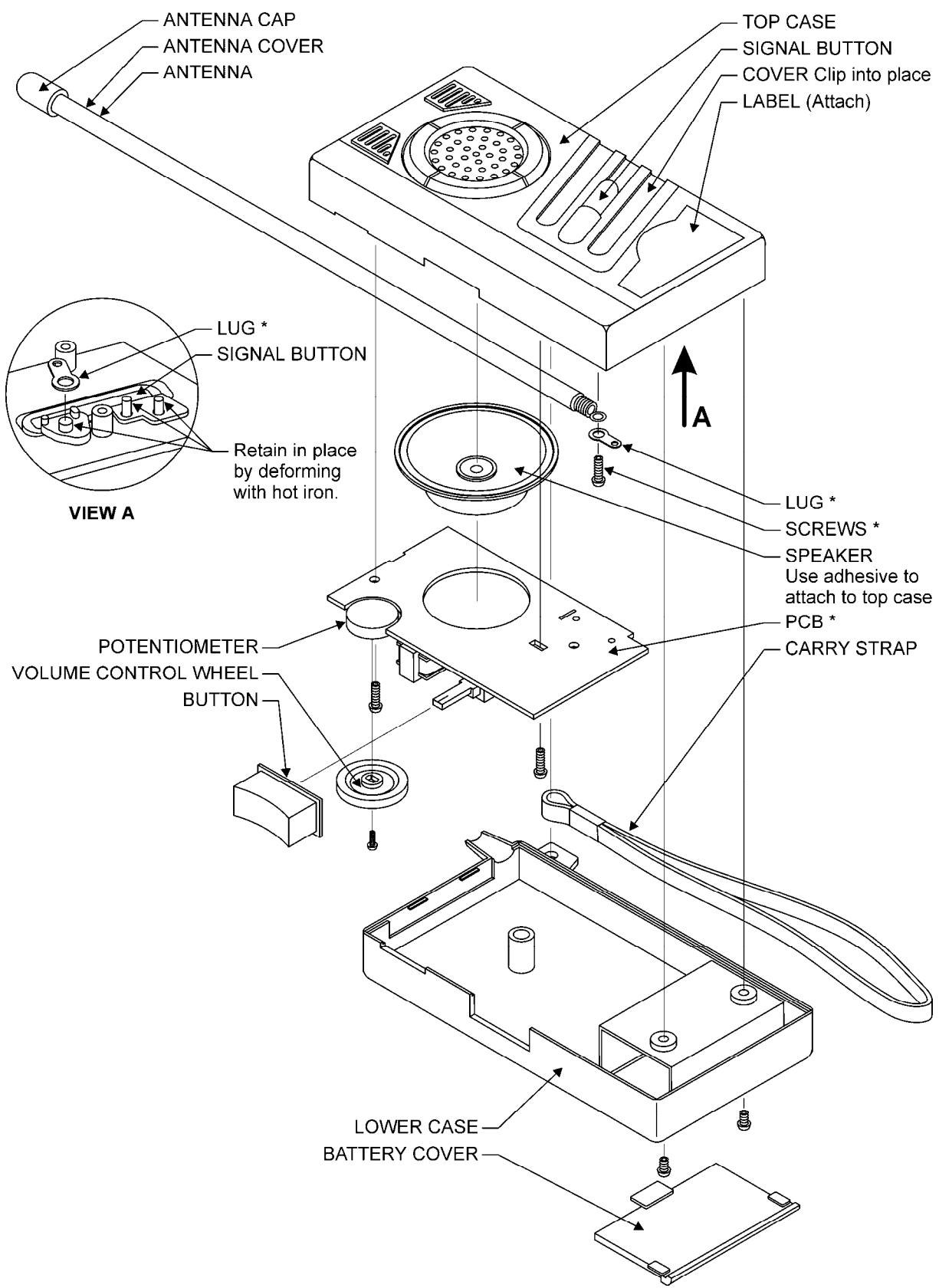

* = PART OF KIT (PLASTIC BAG)

3.2 P.C.B. CONSTRUCTION - THE ASSEMBLY SEQUENCE

The assembly of the components to the P.C.B. should be carried out before soldering the components in place. Begin by placing the components that sit lowest on to the P.C.B. Since the manufacture of the P.C.B, C3 and C17 although labelled on the P.C.B are no longer used. There are also a small number of holes to tracks that are not used.

3.2.1 LINKS

- Bend the 3 tinned copper wire links into the shape of a staple (use the distance between the holes as a guide to their length) and insert them into the wire “link” holes. They should fit flat onto the board.

3.2.2 RESISTORS



- Mount the resistors in place. Begin by bending one lead of each resistor (except for R13) as shown.

Note: Resistors are non-polarised components and do not need to be placed in any particular direction. However, the convention is that horizontal resistors are mounted with the gold band to the right and upright resistors to the bottom. Only one resistor is mounted horizontally (R13) - the remainder are mounted upright. Solder them in position and cut the leads flush with the P.C.B..

3.2.3 DISC CERAMIC and GREENCAP CAPACITORS

- The disc ceramic and the greencap capacitors are mounted next. The disc ceramic capacitors are quite small and, as the name suggests, disc shaped. They are usually a brown colour, but they can also be green. The geencap capacitor is green and of a rectangular shape. Both types of capacitors use the same code to mark their value

Notes:

- If the value of the capacitor is small (less than 100) the value will be printed on it. For values larger than 100 a simple code is used. The value is expressed in picofarad (pF). The first two digits give the numerical value in pF and the third figure is the number of zeroes that follow. In the example shown the 403 is read as 40,000 pF
- This is still an awkward value, as we usually try to represent capacitor values in μF or another unit (to be shown next) so that the number of zeros is reduced to only one.
- To convert pF to μF you divide by 1,000,000, which is very unwieldy. A better solution is to use a new term called nanofarad (nF). This value lies exactly midway between pF and μF . The relationship between nanofarad and picofarad is: $1,000\text{pF}=1\text{ nF}$, and $1,000\text{nF}=1\mu\text{F}$. Thus a $40,000\text{pF}$ capacitor is equal to 40nF .
- Check the codes marked on the capacitors against the components list and insert them where they are marked on the P.C.B..



3.2.4 ELECTROLYTIC CAPACITORS

There are two other capacitors to be mounted - they look completely different to the disc ceramics.

- These are Electrolytic capacitors and look like small tin cans, with two leads coming from one end.
- The two $100\ \mu\text{F}$ capacitors are polarised: that is, they have both positive and negative leads. These must be connected the correct way or the model will not work. The negative leads on the capacitor can be identified by two methods: (1) A stripe on the body of the capacitor marks the negative lead or (2) the short lead is negative. Refer to the P.C.B. to determine the positions of the leads. Solder them in position and cut the leads.

3.2.5 TRANSISTORS

The transistors are the next component to be placed into position. There are two types of transistors used in the *WALKIE TALKIE* and they cannot be swapped or they will be damaged and your *WALKIE TALKIE* will not work. There is a one 2SC1417 and three 9014C transistors.

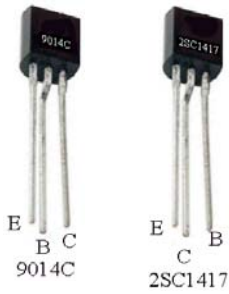

Note: although they look similar, their lead connections are different. Place them in position, checking them against the component list, the PCB pattern and the circuit board pattern shown.

- Solder them in position and cut the leads.

3.2.5 INDUCTOR, TRANSFORMER & SWITCH

The Inductor and the Transformers are next.

- The Inductor is a very small coil of wire wound onto a Ferrite former. Place it in the position marked L1.
- The two transformers look different. One is a Radio Frequency (RF) Variable transformer and can be identified by the visible bare wire. It is also adjustable - it is important that its adjustment is NOT changed.
- Insert the transformers in place and solder in position. Cut back any leads that need to be shortened.
- Insert the push switch and solder into place.

3.2.6 REMAINING COMPONENTS

You will need to refer to the following picture for the positions of the remaining components and wires.

- Find the long rivet, place it in position on the PCB. Use a small piece of masking tape to hold it in position when you turn the board over. Solder the rivet in position.
- The last component to be mounted on the P.C.B. is the Potentiometer. This functions as the combined volume control and on-off switch. Place the potentiometer in the position shown in the picture.
- Insert the two short rivets from the component side of the P.C.B. - they should fit through the holes in the switch's tags. Use small pieces of masking tape to hold the rivets in position when you turn the board over.

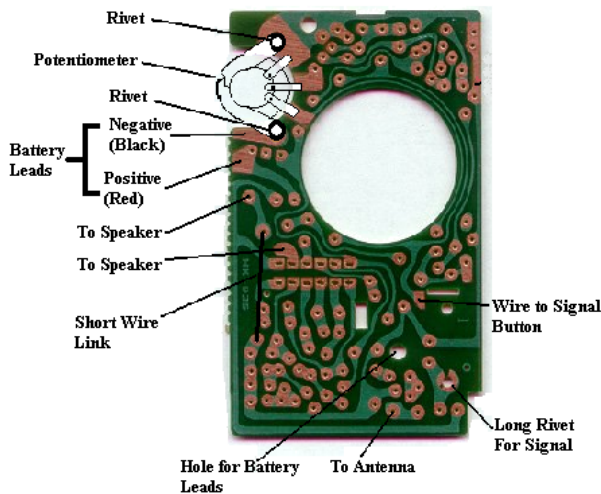

- Solder the rivets in place
- Solder the potentiometer's three tags to the P.C.B..

Check all the components against the P.C.B. diagram to make sure they are correct. It pays to spend a little time now, rather than wasting time later on trying to find out why your project isn't working.

The last parts are the five wires and the battery clip.

- The short wire link is used as a link to connect two tracks on the underside of the P.C.B..
- The wires from the battery clip are passed through the hole shown from the component side. Tie a knot in the leads on the track side of the P.C.B.. The knot should allow the leads to reach their positions as shown. The knot prevents the battery leads from being accidentally torn from the P.C.B. when changing the battery.
- The remaining wires are used for the speaker, antenna and signal switch. Solder the two lugs to the ends of the antenna and signal leads. Be careful with the amount of solder you use on the signal lead as it may get in the way later on.

3.2.7 HOUSING / COMPLETION

- The speaker must be carefully glued in position onto the front casing. Use a hot glue gun carefully place a small line of hot glue around the edge of the casing's circular surround (check how the speaker fits into the surround before beginning).
- Clip the black plastic signal panel into place on the casing.
- The red signal button is fitted into position from the inside of the case. The two holes on the red button fit over the two blues stubs on the case. The red button must be fixed in place, either by melting the stubs (press the end of a heated steel rod on the stubs) or using plastic glue.
- Fit the red plastic knob to the top of the antenna.
- Use one of the self- tapping screws and fit the antenna, with the antenna lug on top, to the post on the left-hand side of the case.
- The signal lug is fitted onto the stub of the red signal button's left-hand side. The end of the lug points towards the speaker. This lug must also be fixed to the signal button by carefully melting the red stud onto the lug as described earlier.

Note: The lug must sit firmly in place, as it forms part of the signal switch. The long rivet (previously soldered in place), forms the other part of the switch. When the signal switch is pressed the lug makes contact with the rivet and a signal for the Morse code is produced.

- Use two self- tapping screws to fix the P.C.B. in place to the front case.
- Check the wiring to ensure it is wired correctly, before connecting power to the circuit – if any components are incorrectly installed, damage may occur to some of the electronic components.

4. TESTING AND EVALUATION

It is more convenient to do your testing before fitting the back casing in place.

- Connect a 9 volt battery onto the battery clip.
- Turn the “ON-OFF” switch to “ON” and adjust the volume to a normal listening level.
- Press the “PUSH TO TALK” button on the side to transmit, and speak in a normal voice level into the speaker /microphone grille.
- Release the “PUSH TO TALK” button to receive.
- The best transmission and reception are obtained with the antenna in the vertical position.
- To send Morse Code signals, press the “PUSH TO TALK” button and hold it down. Press the front signal button. Press and quickly release it to send a dot or hold it longer to send a dash.

Note: You can practice Morse Code without transmitting to other units, by pressing only the signal key (without pressing the “PUSH TO TALK” button).

5. PROBLEMS

If you connect the battery, and the *WALKIE TALKIE* doesn't operate as it is meant to, the following tips are the most likely causes of failure:

- If you hear a high pitched tone it means the rivet and the lug, which form the signal switch are touching. You will need to unscrew the P.C.B and carefully file down the rivet to a shorter length. (Remember to remove the battery while doing this). Fit the P.C.B. in place and try it again - if necessary file down the rivet until the *WALKIE TALKIE* operates as it should.
- Nothing happens or it does not operate as expected. Turn off immediately and check that all the components are in the right position and facing in the correct direction (check against the information in section 3).
- If the components are correct, check your soldering. Make sure there are no dry joints (the soldering may look dry or lumpy). Also check for short circuits where solder connects across from one track to another track.
- There may be faulty / damaged components. Transistors may be tested without unsoldering and pulling them out of circuit, using *SCORPIO TECHNOLOGY's In-Circuit Transistor Tester*.