



PHOTO ELECTRIC EFFECT - Planck's constant

Cat: AP2342-001 (Dual LCD meter digital model with 5 LEDs)

DESCRIPTION: IEC's modern version of the "Photo-Electric Effect" for teaching this very important phenomenon and for the determination of "Planck's Constant" to a reasonable accuracy. A choice of 5 different LEDs of known wavelength provide photons to a cell that generates electrons to create a very small current. A 'backing voltage' is applied to the cell to stop the current flow and this becomes the measurement of the energy level of the photon. These energy levels are plotted against the frequencies of the LEDs.

Improvements to this model include: The backing voltage and the photo-cell current in mA or nA can be viewed together without switching from one to the other. LEDs are used as the specific wavelength light sources instead of an incandescent lamp and colour filters.

DETAILS:

- Photo-Electric Effect instrument requires 12V AC or DC from either a mains PlugPak or from a classroom power supply. Provides 2x digital meters to read Backing Volts and Cell Current at the same time. Controls are for: selection of LED colour, adjustment of brightness or intensity, option of Backing Volts coarse and fine adjustment and selection of Expt.1 in mA or nA and Expt.2. Very quick to use.
- Includes set of 5x LEDs of specific wavelength mounted on a small panel with cable & plug. Mounts on the rear of the instrument. The LED wavelengths are indicated on a label on the rear face of the instrument.
- Includes experiment sheets for using the instrument.

AP2342-001 Photo Electric Effect & Planck's Constant



Physical size: 272x160x110mm LxWxH

Weight: 1.2 kg (including LEDs)

INDUSTRIAL EQUIPMENT & CONTROL PTY.LTD.

61-65 McClure St. Thornbury. 3071 Melbourne. Australia

Tel: 61 (0)3 9497 2555

Fax: 61 (0)3 9497 2166

ap2342-001exp.doc

27-Jul-15

THE 'IEC' PHOTO-ELECTRIC UNIT: description

A bench mounting instrument with 2 digital meters to simultaneously indicate both the current through the internal photo-cell and the backing voltage applied to the cell.

This model requires 12V. AC or DC and the set of 5x LEDs is mounted on a small panel that slides into location in the rear of the unit to place the LEDs directly in front of the cell. A small cable connects the LEDs to the instrument for selection and brightness control.



The image above shows the LED panel positioned correctly and plugged into the instrument. The 12V.AC or DC PlugPak socket (2.5mm diam.pin) and the 4mm banana sockets for powering from school power packs are visible,

An instruction label provides basic assistance to the user in the operation of the instrument to avoid unnecessary reference to the full set of instruction sheets.



This image shows the 5 LEDs grouped tightly to provide good cathode illumination in the photo-cell. A switch selects each LED colour and the brightness or intensity of any colour can be adjusted by the 'intensity' control on the front panel. The photo-cell itself can be seen through the orifice in the rear of the instrument however it is always best to keep the orifice covered by the LED panel so the photo-cell is always in total darkness.

The previous model was illuminated by a 12V light source and the colours were created by using filters. Altering brightness was achieved by selecting different orifices in front of the filter. This new model CAN BE USED in exactly this same way if desired by purchasing a "Lamp and Filter Kit" which provides the lamp, 5x filters and 5x orifices. PA2342-150



FRONT PANEL CONTROLS:

When 12V. AC or DC is applied to the instrument it is automatically ON. There is no ON/OFF switch. When ON, the digital displays will show digits.

- **'WAVELENGTH' ROTARY SWITCH:** Selects the desired LED to throw light on the photo-cell.

Unit for wavelength is 'nanometres' = Metres/ 10^9 . Abbreviation: 'nm'.

Frequency is: $(3000 / \text{nm}) \times 10^{14}$ Abbreviation: 'Hz'

- Blue: 480 nm wavelength (or 6.250×10^{14} Hz frequency)
- Green: 522 nm wavelength (or 5.747×10^{14} Hz frequency)
- Yellow: 583 nm wavelength (or 5.146×10^{14} Hz frequency)
- Orange: 613 nm wavelength (or 4.894×10^{14} Hz frequency)
- Red: 660 nm wavelength (or 4.545×10^{14} Hz frequency)

- **'INTENSITY' ROTARY CONTROL:** Adjusts the brightness or intensity of the light coming from the selected LED. The change of light intensity is to prove the proposal that it is not the amount of light that governs the energy levels of the electrons driven from the cathode of the photo-cell by the photons, but it is the wavelength of the light. The energy level will be found to be close to the same at both high and low light intensity levels down to 30%.

- **'BACKING VOLTS' – COARSE / FINE ROTARY CONTROLS:** Adjusts the DC volts applied to the anode and cathode of the photo cell attempting to completely stop the flow of electrons from the cathode to the anode. The value of this voltage is a measurement of the energy level of the electrons that relate to the selected wavelength of the light. The "coarse" control adjusts the voltage rapidly. The "fine" control adjusts the voltage more slowly to accurately determine exactly zero current flow (zero electrons reaching the anode).

1 nA (nanoamp) is 1×10^{-9} amps. (this is 1/1000th of 1 microamp)

The digital ammeter reads to the very small current of 0.1nA.

- **'VOLTS' AND "NANOAMPS" METERS:** The VOLT meter displays the value of the backing voltage required to bring the photo-cell current to exactly zero. This voltage value is graphed against the frequency of the light to determine Planck's Constant.

The NANOAMPS meter displays the small current passing through the photo-cell in either milliamps or nanoamps (as selected) down to 0.1 nanoamps (amps $\times 10^{-10}$).

- **'EXPERIMENT SELECTION: 1 OR 2:** Exp.1 permits experiments 1a, 1b, 1c, 1d and 1e. The sensitivity can be changed from microamps to the much more sensitive nanoamps. These Exp.1 experiments relate to "Photo Electric" and "Planck's Constant". Exp.2 is for "Characteristic curve of Photo Tube".

CAUTION: It is **most important** that, during an experiment, no light other than the light from the selected LED reaches the phototube. Be careful that the LED panel is fitted correctly to the body of the instrument so no other light can enter the instrument.

THE PHOTOTUBE:

The phototube is the essential part of the instrument. It is an evacuated glass tube containing an electrode shaped like half of a cylinder. At the open mouth of this electrode, another electrode, usually in the form of a straight rod, is positioned at approximately the focal point of the curved surface. Some anodes are in the shape of a rectangular frame.

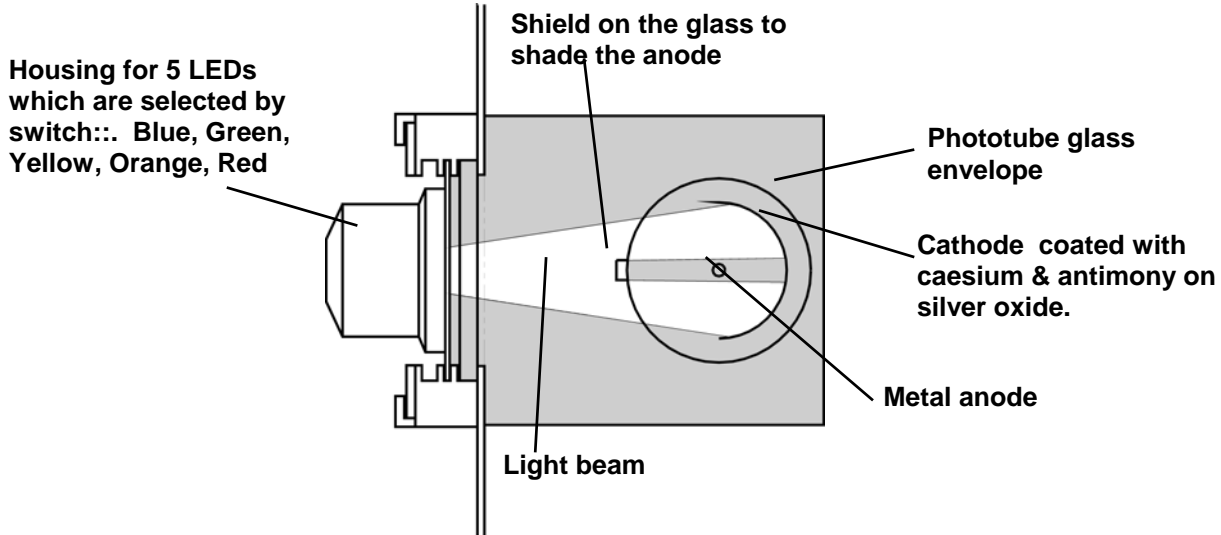

THE ANODE: Light enters the tube to illuminate the cathode. The anode is usually a metal rod to which the electrons flow and it too is illuminated because it stands in front of the cathode. This bombardment of the anode with photons causes the metal surface of the anode rod to release some electrons (an unwanted Photo Electric Effect). Light is reflected also from the glass envelope and from the curved cathode surface itself back on to the anode rod. This anode emission is reduced because it can spoil the migration of electrons from the cathode surface to the anode and therefore create an error when measuring the exact backing voltage required to stop the electron flow from cathode to the anode.

To reduce this error, a shield is usually fitted to the glass envelope of the tube to shield the anode rod from direct light. The reflections inside the tube cannot easily be avoided.

THE CATHODE:

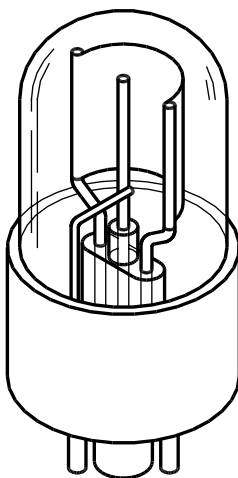

The curved surface of the cylinder is called the Cathode and is coated with a special compound that easily releases electrons when light (or photons) strike the curved surface. This coating is usually a caesium (cesium in the USA) and antimony alloy on silver oxide.

When light strikes the metallic surface, the energy contained in a light Photon is passed to an electron which must first rise to the surface of the cathode material, then overcome the tendency to remain on the surface and finally burst off the surface to travel through the vacuum towards the anode rod.

While light is falling on the cathode, this is occurring billions of times per second and thus an extremely small current is constantly flowing between the cathode and the anode.

This current can be several millionths of an amp (microamps).

ELECTRONS INSIDE THE PHOTOTUBE:

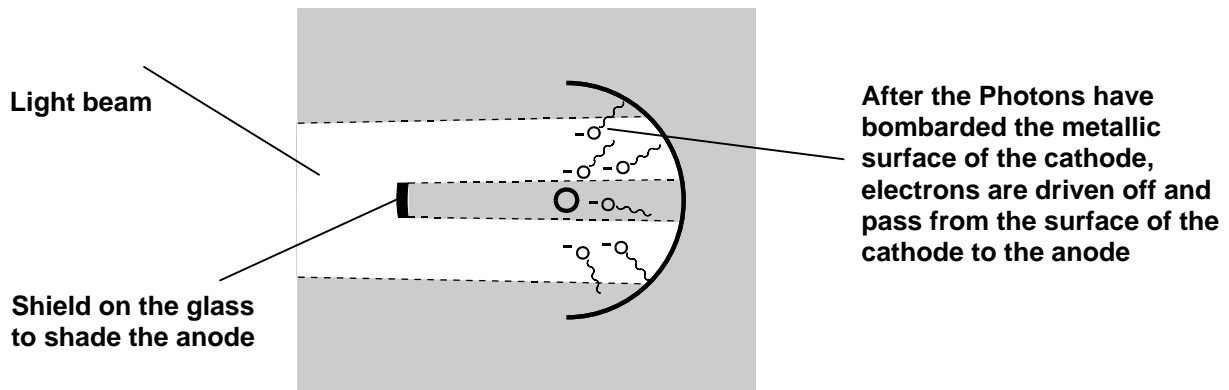

THE PURPOSE OF THE PHOTON ENERGY EXPERIMENT:

To measure the energy of Photons, we need to detect but do not need to measure the current through the phototube. Photons of different energy excite electrons to different energies. The experiment is to **determine the highest energy level** to which the electrons have been excited by the Photons. There will be only a small percentage of electrons flowing from cathode to the anode with these highest energies and we apply a small reverse voltage (anode negative and cathode positive) **JUST high enough to completely stop the flow of electrons**. This reverse voltage is called the Backing Voltage and we need to know the voltage that just stops the last few electrons (those with the highest energy of all).

When **ALL** the electrons stop flowing (absolutely zero current) the voltage has repelled the electrons, including the ones with the highest energy acquired from the photons. It is the energy level of the **highest energy electrons** that interest us for the following reason:

Each LED radiates a narrow range of light wavelengths to produce its colour. We are finding the energy of the photons of the shortest wavelengths (highest frequency) light. The lower frequencies of light produce photons of lower energy and these are stopped as the backing voltage rises. The highest energy electrons are stopped **JUST** at the moment that the current is absolutely zero.

It is important to find **EXACTLY** the backing voltage that is just high enough to stop the last microscopic flow of current. With zero backing voltage, the current flow through the tube may be several microamps. As the backing voltage is increased, the current through the tube reduces to less than a microamp and when it falls to 000.0nA, if the backing voltage is increased more, the current will begin to flow backwards because electrons begin to flow from the anode to the cathode.

NOTE: 1 microamp is 1×10^{-6} Amp. 1 nanoamp is 1×10^{-9} Amp.



EXPERIMENTS RELATING TO PHOTON ENERGY:

A quick overview of the method:

With the Blue LED illuminated at full intensity, we observe the current flowing and we find the backing volts that JUST stops the phototube current. We repeat with each LED at full intensity then plot the backing volts against the highest frequency of light that comes from each LED.

- See the tube current on the NANOAMPS meter and increase the backing voltage to obtain exactly zero current flow. We use the COARSE and then the FINE controls to get the exact point when the current is at zero.
- When the NANOAMPS is at exactly zero, observe the BACKING VOLTS meter and note the value.
- Note the wavelength of the LED selected (displayed on a label on the rear of the instrument) and the backing voltage required for that particular wavelength. The experiment is repeated 3 times using the same LED to obtain an **average reading** of the backing volts **for that wavelength**.
- Select the next LED and repeat the exercise until all LEDs have been used.
- Then convert each wavelength to frequency in Hz and plot a graph of frequency (in Hz) on the X axis against the backing voltage (in Volts) on the Y axis.
- It will be discovered that the line drawn through the points plotted on the graph is a straight line and therefore the energy of the highest energy electrons in each case is directly proportional to the frequency of the light in Hz.

DISCOVER IT IS THE FREQUENCY OF THE LIGHT AND NOT THE AMOUNT OF LIGHT THAT DETERMINES THE ENERGY IN A PHOTON.

- While selecting any LED, reduce the amount of light passing to the photo tube by reducing the intensity of the light. Referring to previous data on that colour LED, we find that very close to the SAME backing voltage stops the current flow. Try other intensities and no matter how much light there is, the maximum energy that is transferred by Photons to the electrons is close to the same. At about 25% intensity, usually the longer wavelength LEDs will not provide stable results.
- Repeat the experiment using each LED running at various intensities.
- This amazing and famous discovery that the frequency of the light determined the energy level and not the quantity of light was made by Maxwell Planck and Albert Einstein. This discovery relates to the famous 'Quantum Theory'.

**Notes on running the experiments: step by step:**

1. Be sure the Cable is securely connected to the instrument and check the digital displays are showing values.
2. At the rear of the instrument, slide the LED panel into the slot designed to accept it. A short cover extends to the instrument to ensure that unwanted light cannot reach the Photo Cell. Plug the multi pin plug into the socket on the rear panel.
3. Select the blue LED and be sure the intensity is on maximum or above 70%. See the NANOAMPS flowing through the tube. Set the FINE control about half way around its travel. Turn the COARSE control clockwise to increase the backing voltage to reduce the cell current to something close to zero. Then use the FINE control to carefully adjust the backing voltage to achieve exactly zero NANOAMPS. If the display shows a negative sign, you have gone past zero and current is flowing backwards. Turn the control anticlockwise to reduce backing volts. If the display reads 000.0 nA, it is OK if the negative sign appears and disappears repeatedly.
- 4.** Take note of both the wavelength of the LED selected and the backing voltage reading. **NOTE:: The wavelength of each LED is indicated on a label on the rear of the instrument.**
5. Using the same LED, reduce the backing volts and again raise the backing volts to JUST achieve exactly zero nanoamps. Repeat the procedure again and find the average of the 3x backing volts readings.
6. Select the next LED and repeat the experiment from 3) to 5) .

From the wavelength (in nanometres) for each LED, calculate the frequency (in Hertz) of the light transmitted by each LED and plot a graph of frequency in Hz ('X' axis) to backing volts in Volts ('Y' axis) for each LED colour.

You should find that all points will come close to falling on a straight line and the gradient of this line is related to '**Planck's Constant**'. From the graph, apply mathematics to determine the experimental value of Planck's Constant.

Also from the graph, the following can be determined:

- The cut-off frequency of the tube.
This is the minimum frequency of light that drives any electrons at all from the surface of the cathode.
- The Work Function ('W') of the tube (in eV .. electron volts).
This is the energy from the photons that is used in performing work on the electrons before electrons are driven free of the cathode surface to pass through the vacuum to the anode. The cathode surface of the Caesium and Antimony alloy provides a very low cathode work factor. Zinc and other metals can release electrons when struck by photons, but the effect is not generous in providing electrons because the work factor of these metals is much higher.

Helpful information:

- As an exercise, if a direct viewing spectroscope is available, measure the shortest wavelength transmitted by each LED and compare with the wavelength (in nanometres) marked on the label on the rear of the instrument.
- This instrument can be used with the traditional white light source and colour filters if desired but these are not provided as part of the kit.
- If a mercury vapour light source is used, a plain glass filter will be required to remove the Ultra Violet content from the light while leaving the shortest visible wavelength present (about 390nm).

If using a mercury vapour lamp, remember that ambient light can enter the instrument when the original LED panel is removed from its mounting. Only light from the mercury vapour lamp should enter the instrument. Be sure to use an opaque barrier of some type to eliminate ambient light from the instrument.

This mercury vapour wavelength would provide you with a 6th point to plot on the graph.

- If an incandescent light source is used, remember that the light will contain a great amount of reddish wavelengths and very little blue wavelengths. If the light source is Quartz Halogen, the blue content will be increased and if the voltage applied to the light is raised, the filament will run hotter and brighter to increase the blue content a little and will reduce the red content.
- IEC produces a "Light, Filter & Orifice Kit" if experiments using white light and colour filters is desired. Part number is: PA2342-150.

**Experiment #1 can be performed in the following areas:**

- a) Demonstrating the Photo Electric Effect ... that light can create an electric current.
- b) Relationship between Illumination of the tube and Current flow through the tube.
- c) Demonstrating that Photon energy is dependent on frequency of the light. Also show that it is a linear relationship.
- d) Planck's Constant ... the amazing relationship between energy and wavelength.
- d) Examining energy distribution of the electrons in the tube.

Discussion: Is light really a **particle** or an **electromagnetic wave** ?

EXPERIMENT 1a): THE PHOTO-ELECTRIC EFFECT

Our laboratory for these experiments is a Photo tube which is a special metal surface and a metal anode both mounted in a vacuum inside a glass envelope. It is said that when Photons of light strike some metallic surfaces, each Photon transfers all of its energy to an individual electron which then has sufficient energy to be released from that metallic surface. Some of the Photon's energy is used up in raising the electron to the surface of the metal and energy is used up in releasing the electron from the electrostatic pull of the surface of the metal.

The remaining energy drives the free electron from the cathode to the anode inside the vacuum tube. This phenomenon is known as the 'Photo-Electric Effect' and provides the basis for several experiments involving the energy levels of light particles.

The 'IEC' Photo Electric Effect apparatus is fully self contained and includes the electronics for detection and amplification of the very small currents involved (nanoamps).

There is no voltage applied to the Phototube, but the light from selected LEDs will fall upon the cathode surface of the sensitive photo tube contained within the apparatus. Electrons are excited and escape from the surface of the metallic cathode to migrate to the anode. This constitutes a very small current of electrons between the cathode and the anode and this current is detected and amplified to be seen on the digital meter.

- Power up the instrument with 12V. AC or DC.
- Remove the LED panel from the rear of the instrument.
- Turn COARSE knob to set Backing Volts to ZERO.
- Observe the NANOAMPS reading.
- Point the rear of the instrument to any light source of white or any other colour so that the Photo Cell is illuminated. The nanoamps meter will show current flowing through the tube caused by photons from the light source striking the cathode surface and driving off electrons.

At this point it can be said that the Photo-Electric effect has been demonstrated.

EXPERIMENT 1b): relationship between ILLUMINATION & CURRENT

- With the LED panel removed and a white or coloured light source illuminating the Photo Cell as in the previous experiment, set the backing volts to zero. Observe the current in NANOAMPS.
- Cut say 4x pieces of cardboard to fit the slide groove in front of the cell. In each cardboard slide, make a hole say 5, 10, 15 and 20mm diameter and be sure it is in line with the hole in front of the photo tube.
- One at a time, slide each card orifice in front of the cell and plot a graph of current through the tube (in nanoamps) against aperture area which is: $\text{area} = (\pi \times (\text{aperture radius})^2)$. It will be obvious that with less total light, the current from the cathode reduces as less electrons are released by the photons striking the cathode.
- The graph should extend in a straight line to zero aperture and zero tube current.

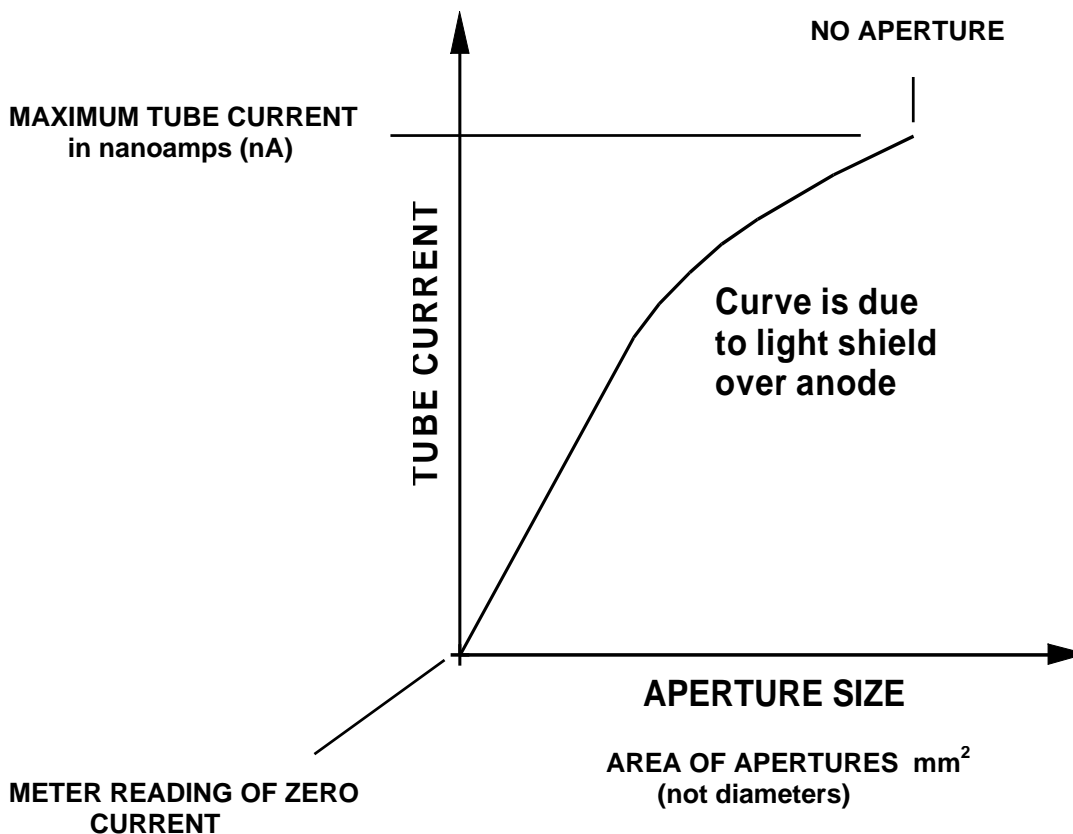



EXPERIMENT 1c): THE ENERGY IN A PHOTON DEPENDS ON THE FREQUENCY OF THE LIGHT

The light from the selected LED (Light Emitting Diode) falls upon the surface of the cathode of the sensitive photo tube contained within the apparatus. When photons fall upon the metallic surface of its large curved cathode, photons transfer their energy to the electrons and the excited electrons escape from the surface of its metallic cathode to migrate to the anode. This constitutes a very small current of electrons between the cathode and the anode and this current is detected to be seen on the meter as MILLIAMPS or NANOAMPS.

The energy of the electrons can be determined by applying a small voltage to the tube in the reverse direction to determine the voltage that stops ALL the electrons from flowing from the cathode to the anode. To obtain the most accurate 'zero current' through the tube, always select NANOAMPS. When the NANOAMPS current is no longer flowing, the value of this voltage is a measurement of the level of energy of the **most energetic** electrons. **This means the electrons that were excited by the Photons of the highest frequency (shortest wavelength) component of the light beam entering the phototube.**

As different colours of LED cause different wavelengths of light to be the highest frequency, it is found that it takes a different backing voltage to stop the current created by the different wavelengths. Therefore the energy of the photon that was transferred to the electron depends on the wavelength (or colour) of the light.

By using the 'Intensity' control on the front panel, it can be discovered that if the AMOUNT or brightness of light is increased or decreased, it makes little difference to the backing voltage required to completely and exactly stop the electron flow. Therefore it follows that the energy in a Photon of light depends on the **wavelength** of the light and does not depend on the **amount or brightness of light.**

At this point it can be said that Photon energy depends on the wavelength of the light.

For each of the LEDs, the value of the highest frequency of the light reaching the phototube ('X' axis) is plotted against the Backing Voltage required to exactly stop the flow of current ('Y' axis). It can be discovered that the line joining the points on the graph is a straight line

At this point it can be said that the energy of a Photon is proportional to the frequency of the light and its energy is higher for higher frequencies (shorter wavelengths).

DISCUSSION: A Photon is behaving like a particle when it transfers energy to an individual electron. Light behaves like a wave when it reflects or diffracts to create interference patterns through slits or gratings.

Discuss how light can be both a particle and a wave.



EXPERIMENT 1d): Analyse data to obtain PLANCK'S CONSTANT

The Theory:

A photon of light has energy ' hf ', as proposed by Einstein in 1905, where ' h ' is a constant and ' f ' is the frequency in Hertz of the radiated emission.

In the Photo-Electric effect, a photon gives up all its energy to an electron in the surface of the illuminated material. The energy is used for three purposes:

- 1) Bringing the electron to the surface of the metal
- 2) Freeing the electron from the metal's electrostatic attraction. The energy required to do all this is called the 'Work Function' ' W ' of the metal (Caesium & Antimony alloy) in the phototube. (chemical symbols Cs & Sb).
- 3) Providing Kinetic energy to the free electron.

It follows then that for a given frequency, the most energetic electrons at the surface of the metal have kinetic energy ' T ' where: $T(\text{max}) = hf - W$ Where ' W ' is the 'Work Function', or the minimum amount of energy required for an electron to be released from the surface of the metal.

The constant ' h ' was first determined by **Maxwell Planck** so it is known as **Planck's Constant**. In the experiment, we must know the UPPER frequency of the light striking the metal surface in the phototube. The LEDs have data information that advises this wavelength and the value is shown on the label on the rear of the instrument. Remember: short wavelength means high frequency.

Each Photon will lose all its energy to an electron in the surface of the metal and the maximum kinetic energy of the electrons can be determined by applying a reverse voltage to the tube so that a retarding electric field **JUST** completely stops the most energetic electrons from reaching the anode. This reverse voltage is called the 'Backing Voltage'.

If this 'Backing Voltage' has a value ' V ', then the energy supplied by the electric field in stopping the emitted electrons from reaching the anode is ' eV ', where ' e ' is the charge on the electron and ' V ' is the backing voltage. This energy equals the kinetic energy of the electrons, so since $T(\text{max}) = eV$ then it follows that $eV = hf - W$

For different wavelengths of light, a graph of ' V ' as a function of ' f ' can be plotted. Its **gradient** will be the **change of ' V ' / the corresponding change of ' f '**.

Divide both sides of formula by ' e ' gives $V = hf/e - W/e$ or $V = f(h/e) - W/e$

This follows the normal straight line formula of: $y = ax + b$

So, the slope of the V/f graph will be h/e and the intercept on the Y axis will be $-W/e$

If the gradient is calculated from ' ΔV ' and ' Δf ', then the value of Planck's Constant ' h ' can be found because the value of ' e ' is known at 1.6×10^{-19} coulomb.

MEASURING THE WORK FUNCTION: The Work Function $W/e = f(h/e) - V$

Multiply through by ' e '. $W = fh - Ve$

**EXPERIMENT 1d): FURTHER INFORMATION:**

To obtain the frequency of the light in Hertz from its Wavelength in nanometres (metres $\times 10^{-9}$), divide the speed of light by its wavelength. Accept the value of 'c' (speed of light) as 3×10^8 metres / second.

EXAMPLE: For a wavelength of 428 nm, the frequency would be:

$$f = 3 \times 10^8 / 428 \times 10^{-9} = 7.0 \times 10^{14} \text{ Hertz}$$

Typical tabulated results:

<i>LED Colour</i>	<i>Shortest Wavelength</i>	<i>Highest Freq. Hz $\times 10^{14}$</i>
Blue	480 nm	6.250
Green	522 nm	5.747
Yellow	583 nm	5.146
Orange	613 nm	4.894
Red	660 nm	4.454

Accept the charge on an electron as 'e' equal to 1.6×10^{-19} coulomb

To calculate the kinetic energy 'T' of the electrons in electron volts, multiply 'e' by the backing voltage 'V'. The gradient of the graphed line is any change in the value of 'V' in volts divided by the corresponding change in value of 'f' in Hertz.

THIS WOULD BE A PERFECT RESULT (but difficult to get):

If the tube performed perfectly and if there were no errors or electron collisions inside the tube and no anode emission, from the graph the gradient should be about 0.41×10^{-14}

Follow this through:: Theory tells us that $h / e =$ the gradient of the graph

$$\text{so, } h / (1.6 \times 10^{-19}) = 0.41 \times 10^{-14} \quad \text{therefore: } h = 0.41 \times 1.6 \times 10^{-33}$$

$$\text{so, 'h' (Planck's Constant) = } 6.6 \times 10^{-34} \text{ joule seconds.}$$

(Planck's Constant is considered to be: 6.626×10^{-34} joule seconds)

A TYPICAL RESULT: Due to differences from tube to tube, internally reflected light from the cathode on to the anode causing electrons to be emitted and other factors beyond our control, the gradient of the line of best fit between the 5x plotted points is never exactly 0.41. **A very small change in slope of the graph can translate to quite a large error.**

Therefore, allowing for graphing errors, a typical gradient is usually about 0.38 to 0.30 instead of 0.41 (errors of between 10% and 30%).

Using the white light and colour filter method, the error is usually similar.

EXPERIMENT 1d): SAMPLE GRAPH:

An example of experimental readings using LEDs as light sources. The results indicate a good set of figures that will give a very accurate result.

Typically, backing volts for the short wavelengths will be approximately 0.8 to 1.0V and the "Y" axis would be intersected at about 1.0V. Typically the slope of the graph will be flatter than this example and therefore the result will be less accurate.

BUT:: The purpose of these experiments is to teach the principles and the relationships between wavelengths and energy levels. Achieving the precise value calculated for Planck's Constant using a Photo Tube is not so important.

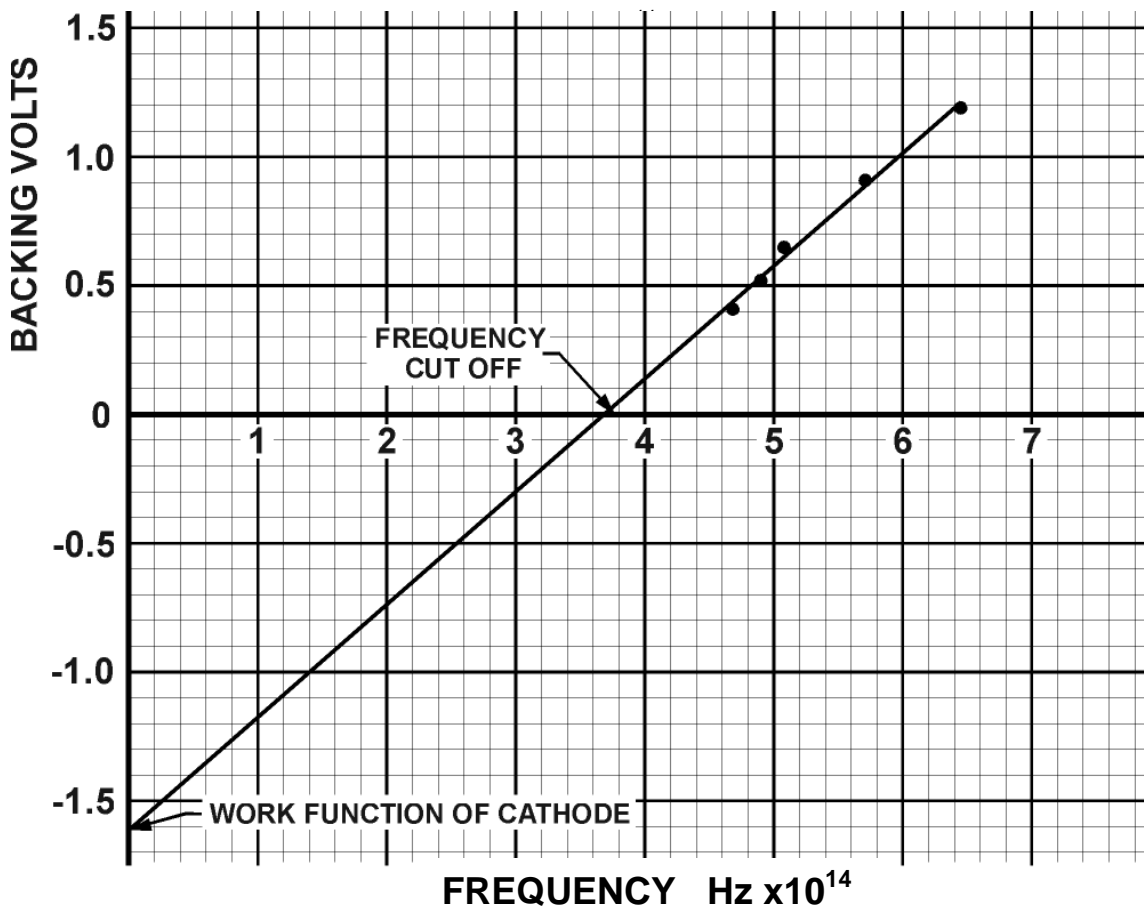

Slope of graph = $\Delta V / \Delta f = 1.50 / 3.77 \times 10^{14} = 0.39 \times 10^{-14} = h/e$

Calculate 'h': (slope) x (e) = $(0.39 \times 10^{-14}) \times (1.6 \times 10^{-19}) = 6.24 \times 10^{-34}$

Error from Planck's Constant: $((6.626 - 6.24) / 6.626) \times 100 = 5.8 \%$ error

Depending on the exact performance and efficiency of the particular Photo Electric tube and other factors causing variations, errors ranging between 5% and 30% can be expected in calculating Planck's Constant. Nevertheless, the method and the theory is clearly demonstrated.

EXPERIMENT 1e): ENERGY DISTRIBUTION:

- Create a graph plotting relative current through the photo-tube against actual Backing Voltage. Remember that current is proportional to the number of electrons and Backing Voltage is proportional to their energy.

By considering the shape of the graph, deduce an energy distribution for the electrons.

Determine:

- What proportion of all the emitted electrons have the maximum energy (highest number of eV) ?
- What proportion have say up to half of the maximum energy ?
- What proportion have say 2/3rd the maximum energy ?

RESULT: Only a small proportion of electrons have high energy, most electrons have low to medium energy.

'NUMBER OF ELECTRONS'
IS THE SAME AS CURRENT.

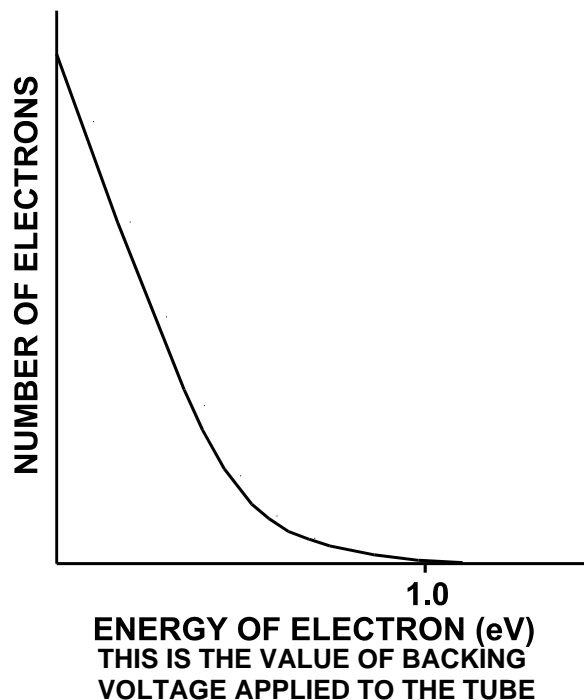

EXPERIMENT 2): CHARACTERISTIC CURVE OF THE PHOTO-TUBE:

CURRENT / VOLTAGE CHARACTERISTIC OF THE TUBE:

Select Experiment 2 and connect the external sockets to an adjustable power supply that can provide adjustable 0 - 20V.DC.and can provide at least a few milliamps. In this experiment the voltage is not a 'Backing Voltage' because, this time, the voltage is applied to the tube in the forward direction to encourage electron flow from the cathode to the anode. This applied voltage can be monitored on the instrument's digital display.

The experiment is to determine the characteristic of the tube by plotting applied voltage against the relative current through the phototube while white light is falling on the cathode.

Use any white light source and do not use filters. Depending on the light source, fit a small aperture to limit the amount of light falling on the cell. If the light is not limited, the current will keep rising beyond the instrument's ability to measure it.

With the controlled amount of light falling on the cell, gradually increase the applied voltage at the 4mm sockets from zero up to about 20V.DC.

Note that the tube current increases with applied voltage as shown in the graph below. Plot the relative phototube current in microamps against the applied forward voltage in Volts to obtain the **characteristic curve** of the phototube.

- Try to explain the shape and the reason for the 'flattening off' of the curve.

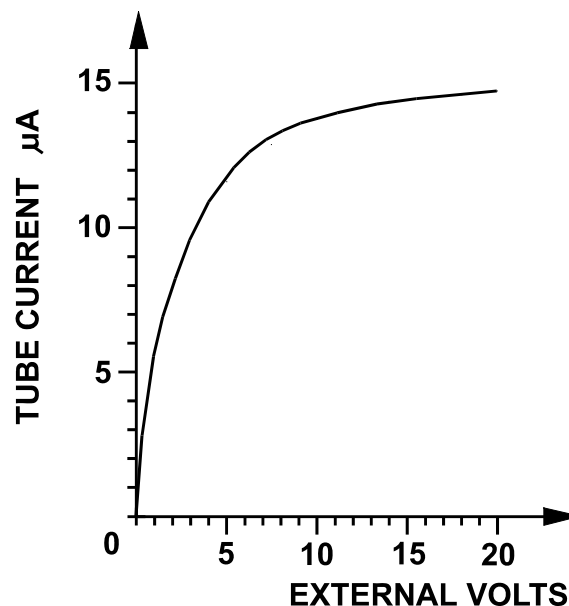

Developed, designed and manufactured in Australia