



SOLAR CAR BASIC - NO SOLDER (Code: SOLARB-NS)

DESCRIPTION

The *SOLAR CAR BASIC-NO SOLDER* is a simple four-wheeled vehicle powered by a single section solar panel producing 3.0 Volts and 0.8 Amps of electricity under a 100% sunlight condition.

Power is transferred from the electric motor to the driven wheel via gears as selected by the student.

This car will run on a smooth level surface from 25% sunlight upwards.

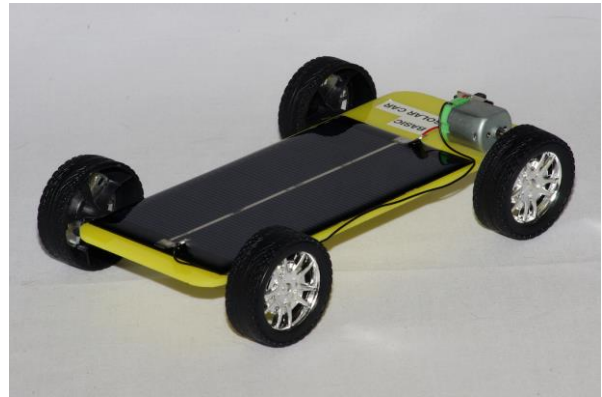

LEVEL:

Introductory

HOURS TO CONSTRUCT:

10 - 15 hours

SKILL DEVELOPMENT:

- Planning and Design
- Manufacturing
- Soldering
- Mechanical
- Electrical
- Alternative Energy

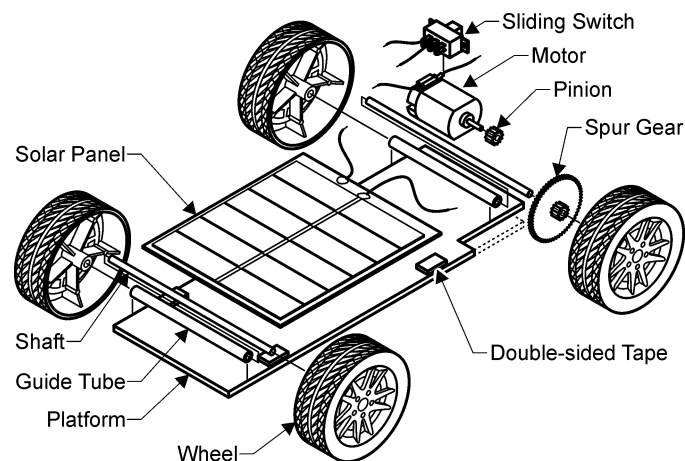



WHAT'S IN THE KIT?

- All the mechanical and electrical components required to make the *SOLAR CAR BASIC – NO SOLDER* work including the solar panel, motor and switch.
- A detailed teaching unit with a complete parts list, design suggestions, general construction guidelines and suggestions for testing and racing the solar cars.

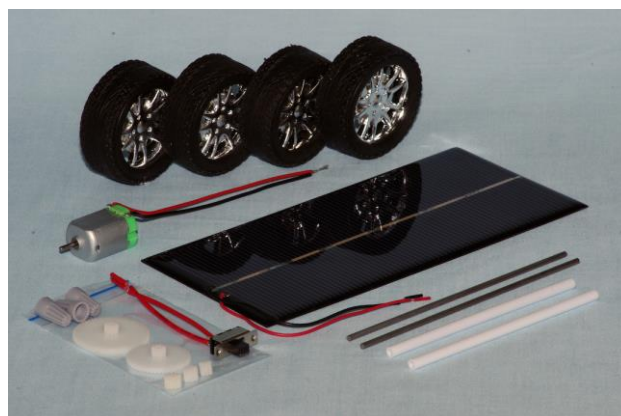

WHAT ELSE IS NEEDED?

The following items are required and are available from Scorpio Technology, but need to be ordered separately:

- Multi strand hook-up wire (WIREHU10)
- Hot glue (GLUESTK) or double-sided adhesive tape (TAPEDS)
- We recommend the following spares when buying class sets of kits to replace parts damaged or lost by students:
 - o Steel rod and Plastic guide tube (SRGTW – 5 of each in a pack)
 - o Wheels - large (W52C2 – pack of 40)
 - o all pinion and spur gears (GEAR8/1.9, GEAR10/1.9, GEAR12/1.9, GEAR50/10/2.4, GEAR60/10/2.4)

The following material is to be supplied by the student / teacher:

- Material for the platform (PVC or acrylic sheet, plywood, etc.)

SUGGESTED ITEMS FOR TESTING

- A calibrated solar panel (SOLAR10) that is used with a multimeter to show the percentage of sunlight at any given time
- A Multimeter (MULTIM) paired with the SOLAR10 displays the sunlight efficiency

TOOLS REQUIRED

The following tools are required:

REQUIRED TOOLS	ORDERING CODE
Assorted hand tools (depending on materials used)	-
Hammer	HAMMERC/HAMMERCL
Ruler and pen	-
Craft knife	CRKNF
Wire strippers	WIRESTR
Side cutters	SIDECUT or SIDECUTM
Drill Bit – if using guide hooks	-
Mini Bolt Cutters	BOLTCUTM



ABOUT THE PROJECT

The major features of this project are the planning, design, construction and assembly stages of a simple solar vehicle.

DESIGN PHASE

- Create your own unique *SOLAR CAR BASIC* design based on our drawings. Focus on component relationships, rather than dimensions. This provides scope for students to individualise their *SOLAR CAR BASIC* design and increase their engagement in the project.

During the **Design phase**, students will need to:

- Evaluate the suitability of various materials, such as PVC, acrylic, plywood or balsa wood
- Determine which gears will be used from the selection of spur and pinion gears provided
- Investigate the possibility of adding steering
- Determine if forward/reverse operation is desired (additional components will be required such as a three-way toggle switch or our large slide switch)
- Evaluate available technologies that can be used, for example:
 - 3D printer
 - laser cutter (which allows more interesting shapes than usual)
 - vacuum former
- Take into account weight distribution and ease of operation
- Consider the practical aspects of construction and assembly. For example, clearance for the wheels

MAKING / CONSTRUCTION

Once the Design process has been completed, the students will be able to start **building their design**. They will:

- Make and assemble the *SOLAR CAR BASIC* platform they have designed
- Mount the solar panel, motor, switch, axles and wheels on to the platform
- Wire up and solder the solar panel, motor and switch
- Test and adjust the *SOLAR CAR BASIC*
- Troubleshoot any problems!

DOES THE TEACHING UNIT INCLUDE ANY THEORY?

The Teaching unit has a THEORY section that covers

- how solar panels (photovoltaic cells) work
- temperature effects on the power produced by solar panels
- the effect of joining 2 solar panel arrays in parallel
- How to calculate
 - average speed,
 - average acceleration and
 - end velocity

